

COM Express Compact Type 6

Carrier Board

User Manual | 12010

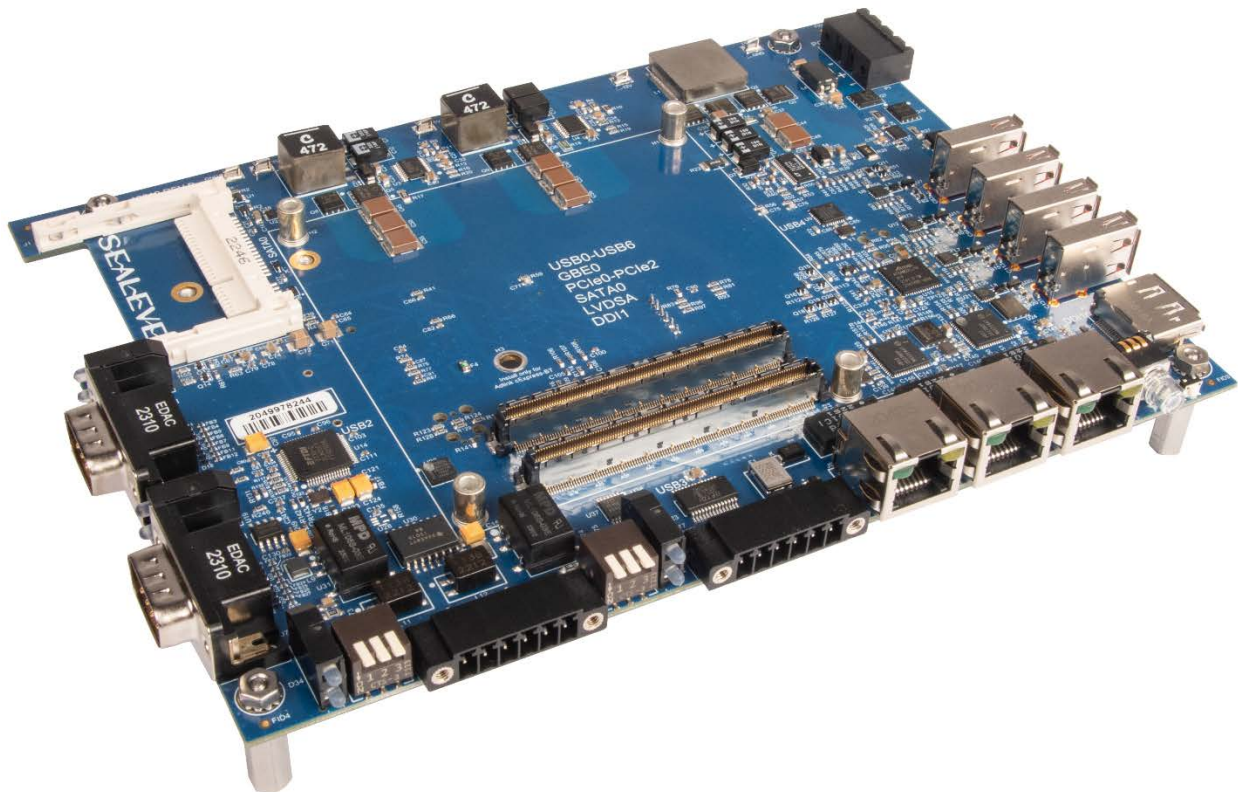

SEALEVEL®

Contents

INTRODUCTION	4
FEATURES	5
BEFORE YOU GET STARTED	6
WHAT'S INCLUDED	6
ADVISORY CONVENTIONS	6
OPTIONAL ITEMS	7
TECHNICAL SPECIFICATIONS.....	8
DIGITAL I/O.....	8
TECHNICAL DESCRIPTIONS.....	9
COM EXPRESS MODULE OPTIONS	9
12010 BLOCK DIAGRAM	9
STANDARD PORTS/CONNECTORS.....	10
<i>DisplayPort Output (P2)</i>	10
<i>cfast for solid-state disk (sata0)</i>	11
<i>mPCIe Expansion Slot (CN1)</i>	12
<i>Ethernet (J10, J11, & J9)</i>	13
<i>USB (J4, J5, J6, & J8)</i>	13
<i>RS232 Communications (J3 and J7)</i>	14
<i>RS485 Communications (J12)</i>	15
SERIAL, DIGITAL OUTPUTS AND POWER.....	16
<i>Input Power (P1)</i>	16
<i>Open Drain Outputs (j13)</i>	17
ADDITIONAL FEATURES.....	19
<i>RTC Battery (BAT1)</i>	19
<i>Onboard Status LEDs</i>	20
<i>Switch (SW4) – Test Enable</i>	22
<i>Switch (SW5) – AT Mode</i>	22
<i>Switch (SW3) – RTC Reset</i>	22
SYSTEM OPERATION	22
POWER STATES	22
EXTERNAL POWER BUTTON.....	22
RESET BUTTON (BP1).....	23

SOFTWARE INSTALLATION.....	23
SEAMAX APPLICATION SUITE	24
SEAMAX OVERVIEW	24
SEAMAX WINDOWS INSTALLATION.....	24
MAXSSD CONFIGURATION & DIAGNOSTIC UTILITY	24
MAXSSD CONNECTION TAB.....	25
MAXSSD DEVICE TAB.....	26
APPENDIX A – TROUBLESHOOTING SERIAL COMMUNICATION ISSUES	30
TROUBLESHOOTING/VERIFICATION FOR ASYNCHRONOUS SERIAL PRODUCTS.....	30
APPENDIX B – HOW TO GET ASSISTANCE.....	33
APPENDIX C – BOARD DIMENSIONS.....	34
12010 TOP VIEW	34
12010 BOTTOM VIEW.....	34
APPENDIX D – HANDLING INSTRUCTIONS	35
ESD WARNING	35
<i>Electrostatic Discharges (ESD)</i>	35
<i>Grounding Methods</i>	35
APPENDIX E – BOARD PHOTOS.....	36
FRONT I/O CONNECTORS	36
SIDE (LEFT) I/O CONNECTORS	36
SIDE (RIGHT) I/O CONNECTORS - NEED NEW IMAGE	36
12010 ADDITIONAL VIEWS.....	38
APPENDIX F – COMPLIANCE NOTICES.....	39
WARRANTY.....	40

Introduction

Get your COM Express project off to a fast start with Sealevel's 12010 COM Express Compact Type 6 Carrier Board. The 12010 supports Compact Type 6 COM Express modules. Standard features include three Gigabit Ethernet ports, four USB 2.0 ports, four open drain digital outputs, two non-isolated RS232 serial ports, two isolated 422/485 serial ports, one mPCIe slot, one CFast slot, and one DisplayPort. Specific features are COM Express module dependent.

Sealevel's 12010 simplifies software development and prototyping while the target application carrier board is designed. Take advantage of Sealevel's carrier board development services for the fastest time to market. Our extensive library of proven I/O circuits including serial, analog, and digital functionality simplifies the design process and can be easily optimized to meet the specific I/O count, voltage ranges and connector types required for your application.

The 12010 COM Express Compact Type 6 Carrier Board is an off-the-shelf Computer on Module (COM) containing the functionality common to most industrial computing systems (processor, memory, graphics, USB, Ethernet, etc.) with a custom carrier board that includes application specific I/O and interface connectors. This combination provides the benefits of a full custom design while reducing the time, cost, and risk of full custom system design.

COM architecture offers significant technical and business advantages including:

- Fast Time to Market
- Scalability for Easy Upgrade
- Superior Application Specific I/O
- Flexible Mechanical Configuration
- Shock and Vibration Resistant
- Extended Operating Temperature Range
- Long Term Availability and Support
- Lifecycle Management and easy technology refresh

Sealevel has partnered with the leading COM Express module manufacturers to ensure our customers benefit from the best in the industry. This manual will focus on the higher-level features of the 12010 carrier board interfaces and I/O.

Features

- Designed for the congatec® conga-TCA7 COM Express family
- -40°C to 60°C wide operating temperature range
- (3) Gigabit (10/100/1000BaseT) Ethernet ports
- (4) USB 2.0 ports
- (4) Open Drain outputs / 100mA capability
- (2) Non-isolated 232 ports
- (2) Isolated 422 / 485 ports
- (1) DisplayPort Connector
- (1) mPCIe expansion slot
- (1) CFast slot
- Onboard LED indicators for power and COM activity
- Real-time clock
- 21VDC input (2 position) Molex Eurostyle connector
- 196.85mm x 146.05mm dimensions

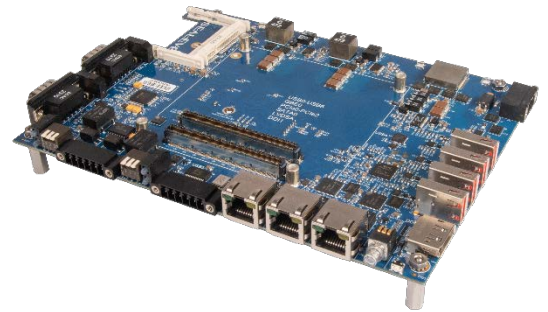

Before You Get Started

What's Included

The 12010 COM Express Type 6 Carrier Board is shipped with the following items. If any of these items are missing or damaged, please contact Sealevel at 864.843.4343 for a replacement.

- **Carrier board**
- **2-POS terminal block for power input**

Advisory Conventions



Warning

The highest level of importance used to stress a condition where damage could result to the product, or the user could suffer serious injury.



Important

The middle level of importance used to highlight information that might not seem obvious or a situation that could cause the product to fail.





Note

The lowest level of importance used to provide background information, additional tips, or other non-critical facts that will not affect the use of the product.

Optional Items

Depending upon your application, you are likely to find one or more of the following items useful with the 12010. All items can be purchased from our website (www.sealevel.com) or by calling our sales team at (864)-843-4343.

100-240 VAC to 24 VDC @ 2.7A, Desktop Power Supply (Item# TR152)	
<p>The TR152 is a desktop (brick style) power supply rated for 100-240VAC input and 24VDC output at 2.7 amps. The cable has tinned leads for use with products that have screw terminals for input power.</p>	
TCA7 COM module kit with 8GB of RAM (Item# 106579-8GB-KT)	
<p>The 106579-8GB-KT is a module kit with a conga-TCA7 Elkhart Lake COM module, 8GB RAM, finned heatsink, and installation hardware.</p>	

Technical Specifications

Environment & MTBF	
Operating Temperature	-40 to 60 °C (-40 to 140 °F)
Storage Temperature	-20 to 80 °C (-4 to 176 °F)
Humidity	10 to 90% R.H. Non-Condensing (Both)
Mean Time Between Failure ¹	683,895 hours at 30° C ambient
Mechanical	
Board Length / Envelope	7.75in (196.85mm)
Board Width / Envelope	5.75in (146.05mm)
Board Height / Envelope	.75in (19.05mm)
Weight ²	.54 lbs / .244 kg
Power Consumption	
Typical Power Draw ³	9.6W
Nominal Supply Voltage	+21 VDC
Nominal Current Draw	450mA

1. Telecordia SR-332, Issue 4 method used.
2. Weight includes board only.
3. Typical power consumption can vary depending on COM Express Module, memory capacity, OS/software activity and peripheral devices. Input power (J7) is current limited by a 5A input protection circuit with overcurrent protection.

Digital I/O

Detailed pinout and wiring information is available in the [Open Drain Outputs \(J13\)](#) section.

Darlington (Open Drain) Output	4 Channel
Derated Voltage	30 VDC max
Max Continuous Drain Current	400mA (100mA per channel)
Max Peak Pulse Current	2000mA

1. Sourced directly from the protected input power.
2. Depends on the input voltage (P1) provided to the device.
3. Be aware of the 5A current limit on the power input (P1) because the load drawn from this output will be reflected in the overall input current.

Technical Descriptions

COM Express Module Options

The 12010 carrier board is compatible with the Compact form factor Type 6 COM Express modules powered by 8th generation Intel® Core™ SOC processor up to 4 cores. COM Express is a widely supported implementation of Computer on Module (COM) design. The COM Express architecture reduces the complexity, cost and time required for custom computer system design by combining the processing, memory, video, Ethernet, and USB functionality in a small, highly integrated module. COM Express modules are installed on a carrier board that provides the application specific I/O and external connectors best suited for the system requirements.

Our COM Express carrier boards leverage Sealevel's I/O and communication expertise, providing carrier board and full system solutions as rapidly as possible. Common I/O features include serial, analog and digital I/O. Sealevel's extensive library of proven I/O circuits can be included to meet a specific I/O count, voltage range, and connector type.

12010 Block Diagram

The 12010 block diagram is shown below with added board reference designators (component addresses). These designators correspond to the board connectors and diagrams on the following pages.

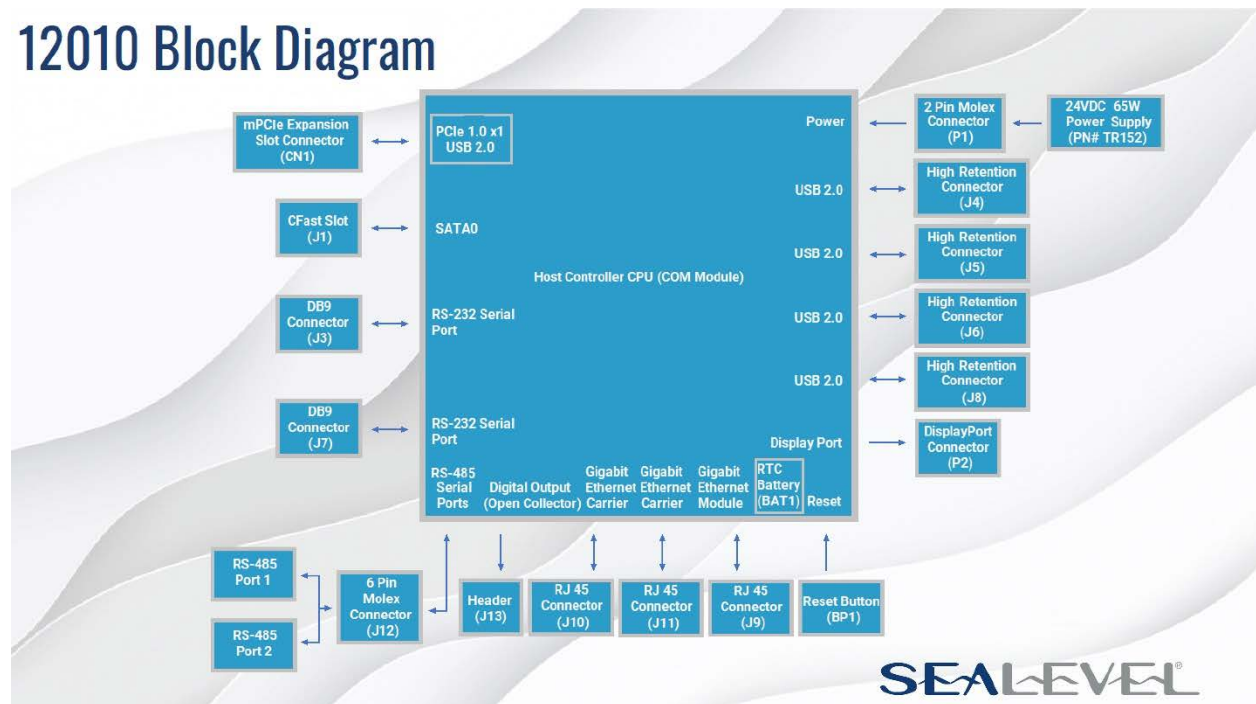

Standard Ports/Connectors

The following I/O connectors use industry standard pin outs for maximum compatibility. All other connectors use non-standard or custom pin outs and are detailed later in the manual.

DISPLAYPORT OUTPUT (P2)

The carrier board includes a DisplayPort connector. The graphics capabilities are dependent on the COM Express module installed.

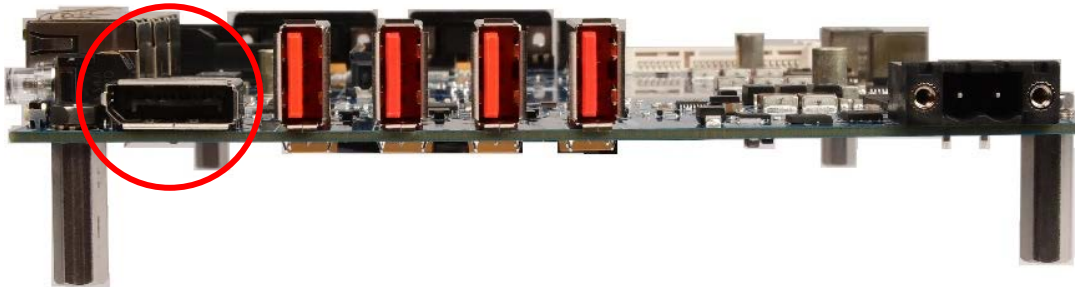

DisplayPort (P2) Location

Function	Connector Type
Digital Video Output	DisplayPort



CFAST FOR SOLID-STATE DISK (SATA0)

The carrier board has a single CFAST connector for adding solid-state disk storage. The maximum capacity and throughput are dependent on the CFAST card and COM Express module installed.

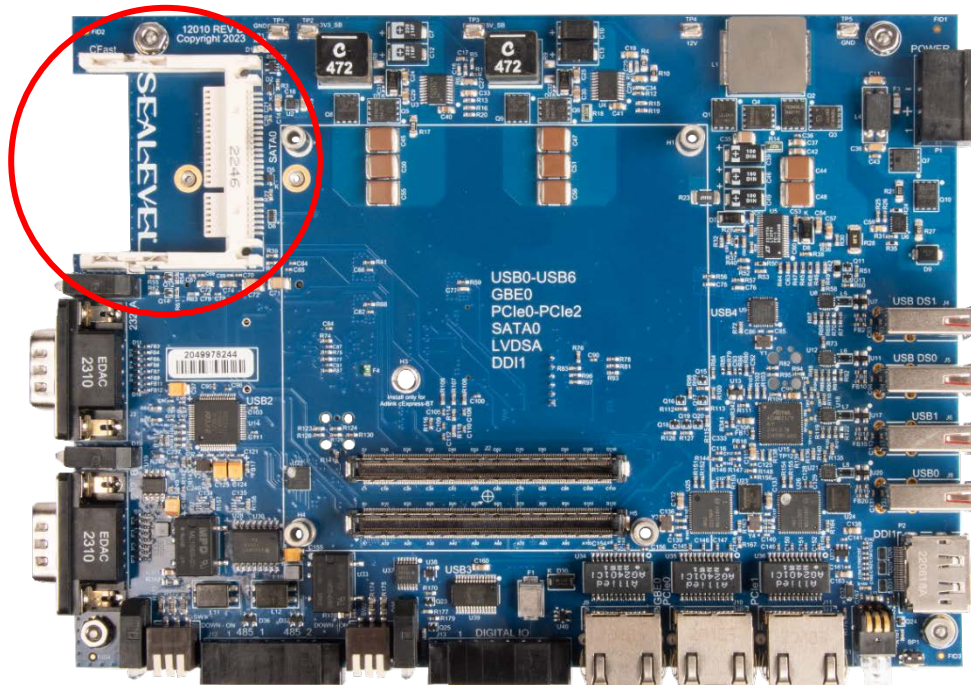

Cfast Slot Location

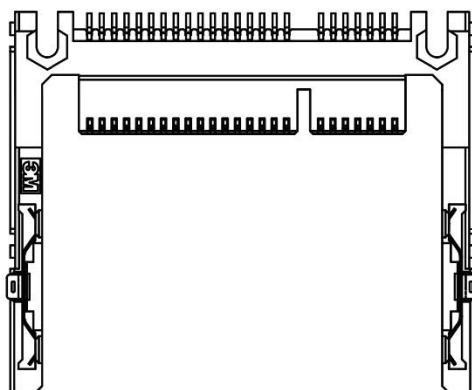

MPCIE EXPANSION SLOT (CN1)

The carrier board has a single mPCIe expansion slot connector. The mPCIe slot supports PCIe 1.0 x1 speed (2.5Gb/s) and USB 2.0.

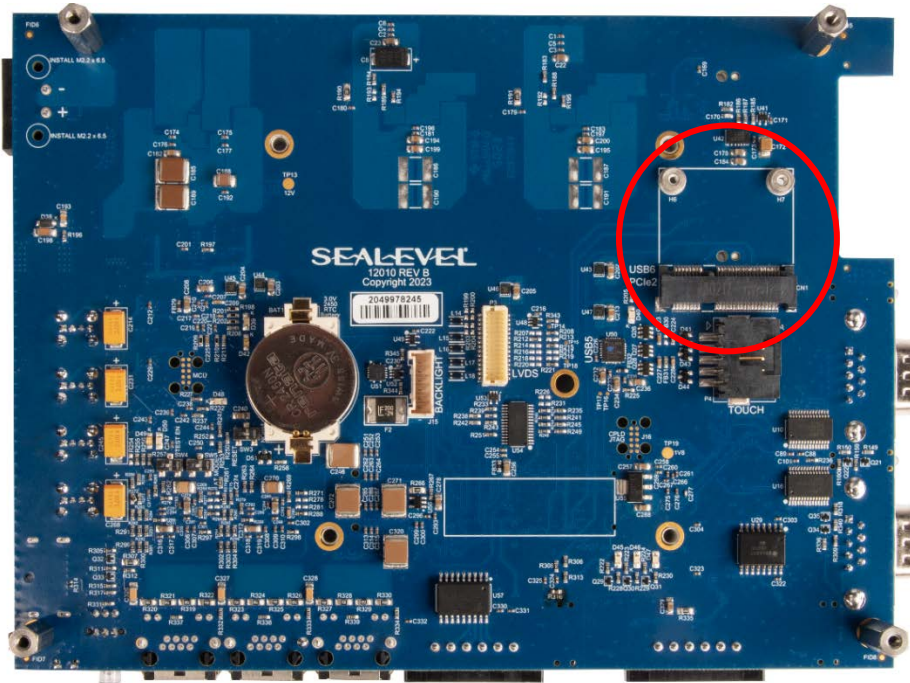

mPCIe Expansion Slot Location

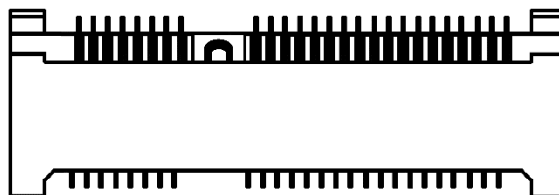

ETHERNET (J10, J11, & J9)

The carrier board has three Gigabit Ethernet (10/100/1000) network ports with LED status indicators for link and activity on the connector. One Gigabit Ethernet port is derived from the COM Express module while the other two are Intel I210IT PCIe NIC on the carrier board.

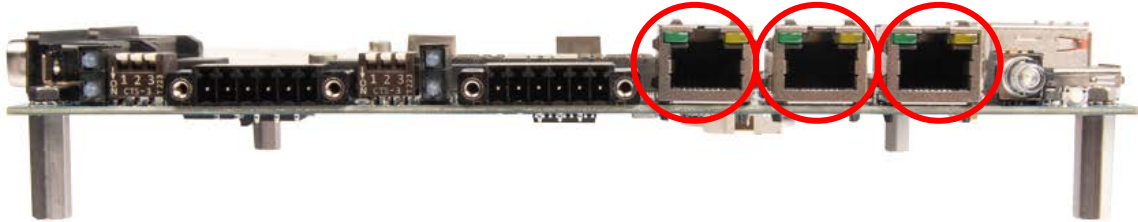

Ethernet NIC Headers (J10, J11, & J9) Location

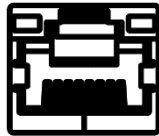

J10 & J11 come from the Carrier Board

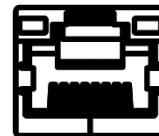
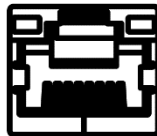

J9 comes from the COM module

USB (J4, J5, J6, & J8)

Four standard USB 2.0 ports. USB J4 and J5 come from carrier 2-port hub. USB J6 and J8 are derived from the COM Express module.

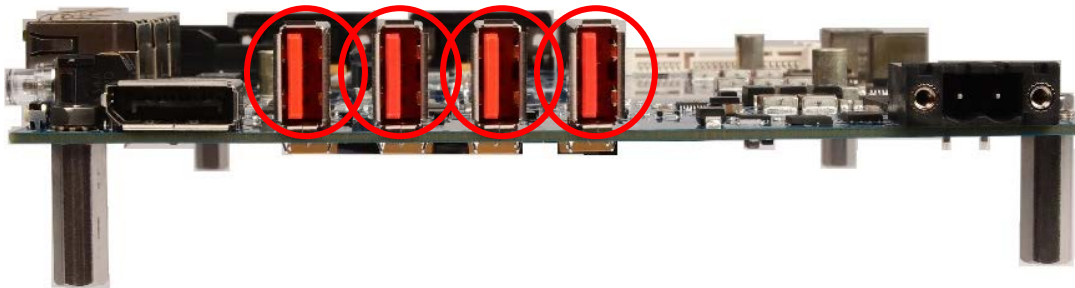

USB 2.0 Headers (J4, J5, J6, & J8)

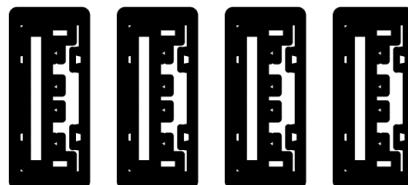

RS232 COMMUNICATIONS (J3 AND J7)

The carrier board has two non-isolated 232 serial ports. All signals: Transmit, Receive, Ground and modem controls are available on a DB9 connector (TE Connectivity Part# 5747840-3). The serial ports are derived from the (USB2 data lines) supplied by the COM Express module and passed through to FTDI USB to UART bridge (FT4232HL).

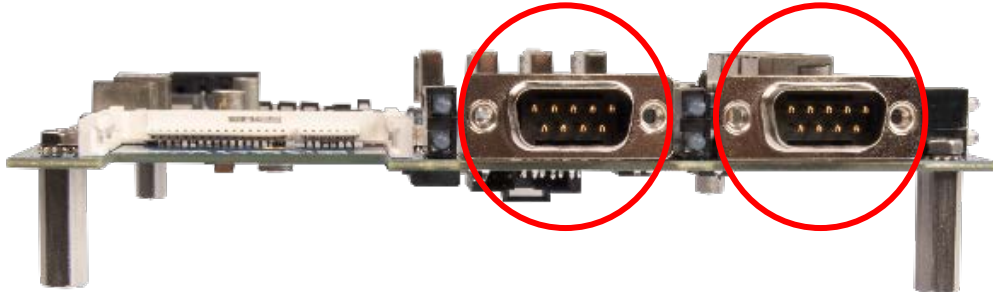

Serial Port Headers (J3 and J7) Location



Pin	Signal	Notes
1	DCD	Data Carrier Detect (DCD)
2	RX	Port 1 Receive (RS232)
3	TX	Transmit (3.3V CMOS)
4	DTR	Data Terminal Ready (DTR)
5	GND	Ground
6	DSR	Data Set Ready (DSR)
7	RTS	Request To Send (RTS)
8	CTS	Clear To Send
9	RI	Ring Indicator

RS485 COMMUNICATIONS (J12)

The carrier board has two Isolated RS485 serial ports. Data + , Data - and Isolated Ground for both RS485 ports (RS485 port 1 and RS485 port 2) are available on the 6pin Molex connector ([Part# 395061006](#)). The serial ports are derived from the (USB2 data lines) supplied by the COM Express module and passed through to FTDI USB to UART bridge (FT4232HL) .

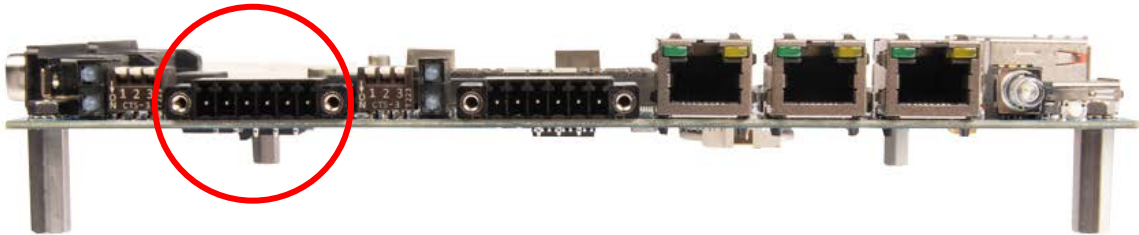

Serial Port Header (J12) Location

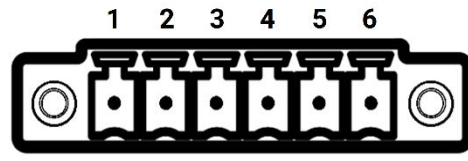

Pin	Signal	Notes
1	ISOGNDA	Isolated Ground A (Port1)
2	DATA 1 +	Positive data line (Port1)
3	DATA 1 -	Negative data line (Port1)
4	ISOGNDB	Isolated Ground B (Port2)
5	DATA 2 +	Positive data line (Port2)
6	DATA 2 -	Negative data line (Port2)

Serial, Digital Outputs and Power

INPUT POWER (P1)

All necessary system voltages are generated from a single 21 VDC input via a 2-position Molex connector. The design includes power protection circuits for under/over voltage and reverse voltage.

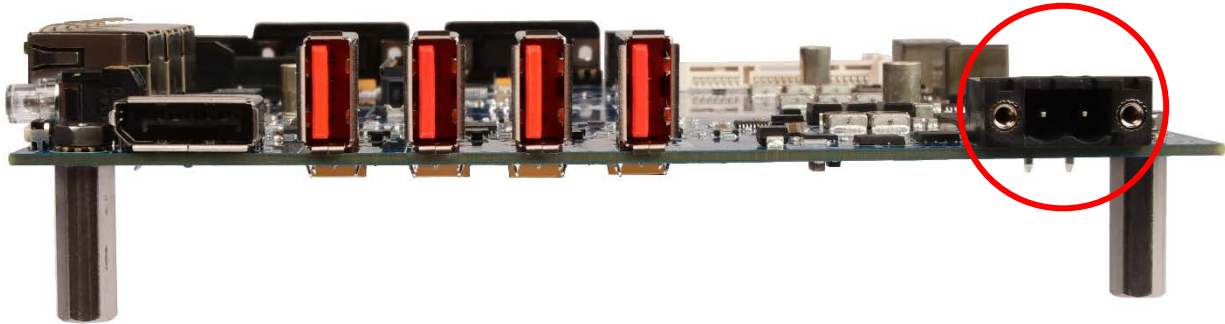

Input Power Connector Header (P1) Location

Reference Designator	Reference	Signal
P1	1	VIN(+)
	2	GROUND

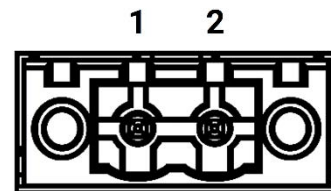

Rated Input Voltage	21 VDC
Acceptable System Input Voltage	10 VDC – 30 VDC
DC Current Rating (21V Nominal)¹	400 mA
DC Current Rating (Max value)	2.5 A max

1. May be higher depending on COM Express module, input voltage, OS, load, and connected devices.

OPEN DRAIN OUTPUTS (J13)

The 12010 is equipped with 4 open drain outputs available on the J13 connector ([Molex Part# 39506-1006](#)).

To view the I/O specifications, see the [Digital I/O](#) section under Technical Specifications.



The Digital I/O is not isolated from the main system power. If using a secondary power supply, it must share the same ground reference as the main system power (P1).

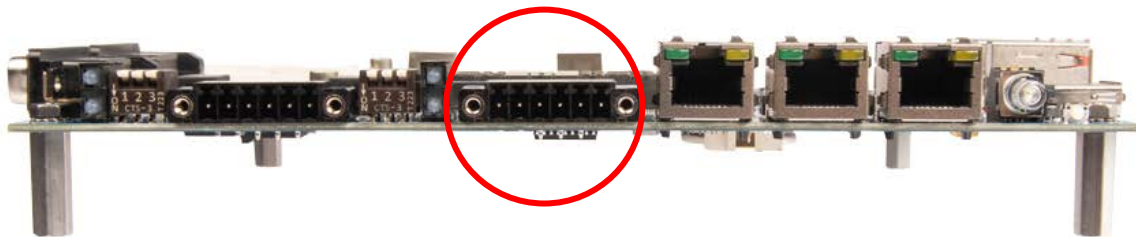

Digital I/O Header (J13) Location

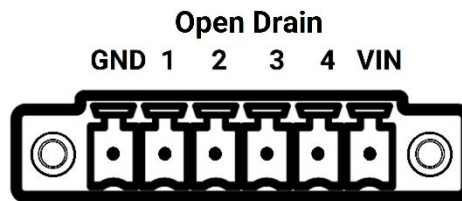

Connector	OPEN DRAIN
Manufacturer:	MOLEX
Part Number:	39506-1006
Description:	6 Position Right Angle 3.5mm Header
Mates with:	MOLEX 39504-0006 6-Position 3.5mm Pluggable Screw Terminal
Screw Torque:	5.5 in lbs. (0.62 Nm)
Wire gauge:	AWG 16-30 (1.31mm ² – 0.05mm ²)

Pin	Signal
1	GND
2	Output 1
3	Output 2
4	Output 3
5	Output 4
6	VIN

OUTPUT WIRING EXAMPLES

The 12010 supports multiple wiring options for the Open Drains for maximum flexibility depending on your power source. Each option is described below.



Each open drain circuit in the array (ULN2803A) contains a suppression diode for inductive load protection. These diodes are only utilized if VIN is connected.

INPUT POWER (P1) WIRING EXAMPLE

Power to the Open Drain Outputs is provided by the system input power (P1) and is accessible from the VIN pin. The outputs are protected from inductive loads via an internal flyback diode.

Open Drain Digital Outputs

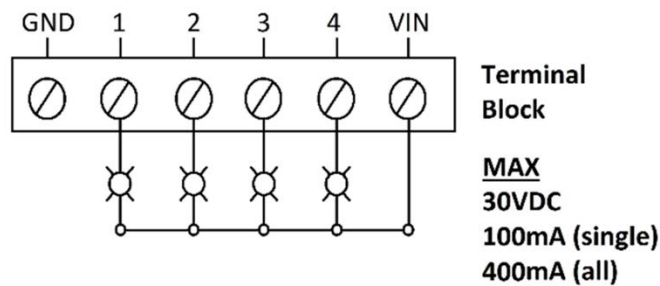

EXTERNAL POWER WIRING EXAMPLE (WITH INTERNAL FLYBACK PROTECTION)

Under some scenarios, you can utilize the internal flyback diodes when using an external power source. This scenario is only possible if your external power source is a higher voltage than the voltage provided on the power input (P1). Refer to the next section if your external voltage source is lower than the Input Power (P1).

Open Drain Digital Outputs

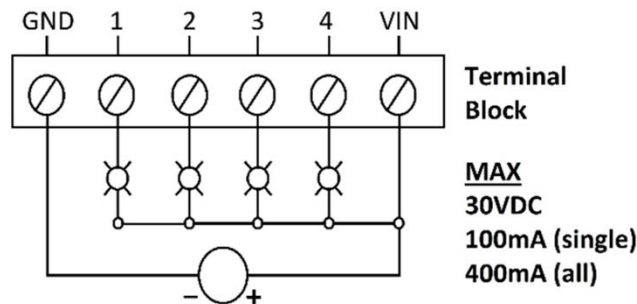

These outputs are polarized but do not have reverse polarity protection. Be mindful of the polarity when connecting your power source.



Your external power source must have a higher voltage than Power Input (P1)

EXTERNAL POWER WIRING EXAMPLE (WITH AND WITHOUT EXTERNAL FLYBACK PROTECTION)

Voltage can be provided independently 12010 power supply if VIN is not connected. However, this also removes the integrated flyback protection. You will need to add your own flyback diodes if you are switching inductive loads.

Open Drain Digital Outputs With Flyback Protection

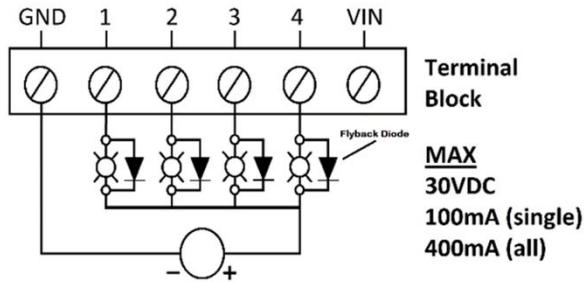

Open Drain Digital Outputs Without Flyback Protection

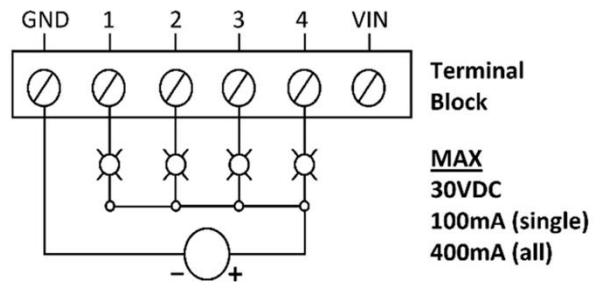

External flyback diodes are required to protect the outputs when switching inductive loads.

Additional Features

RTC BATTERY (BAT1)

The carrier board includes a non-rechargeable, long-life Lithium battery (3V CR2450N) for maintaining RTC/CMOS settings.

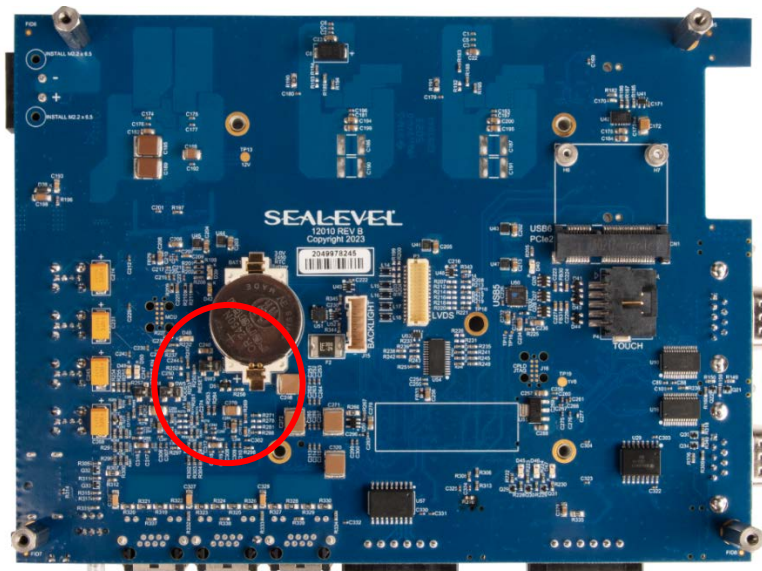

RTC Battery (BAT1) Location

ONBOARD STATUS LEDs

The carrier board includes several status LEDs to show system status or alert to potential problems. The LED location on the board and their functions are detailed in the table below.

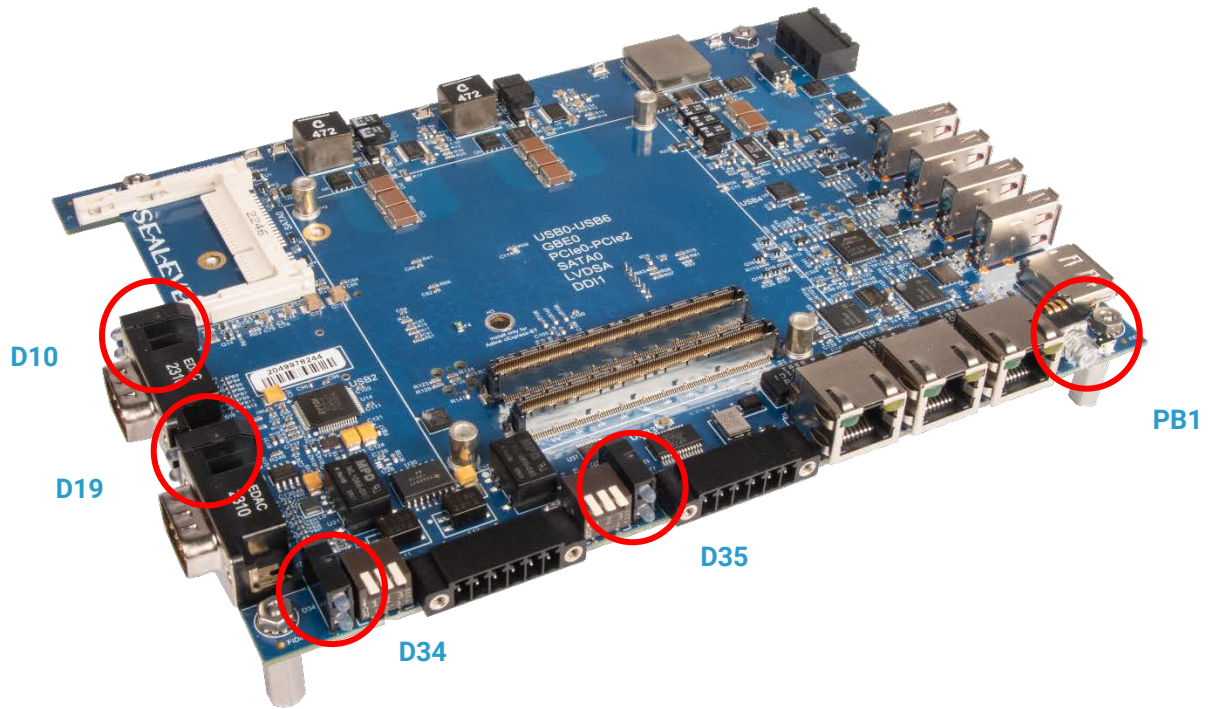

LED and Power Button Locations on Top Side of Board

LED	Signal	Notes
D10	RS232 Serial Port 1	Green TX, Yellow RX
D19	RS232 Serial Port 2	Green TX, Yellow RX
D34	RS485 Serial Port 1	Green TX, Yellow RX
D35	RS485 Serial Port 2	Green TX, Yellow RX
PB1	PWR button	Solid green to indicate board power

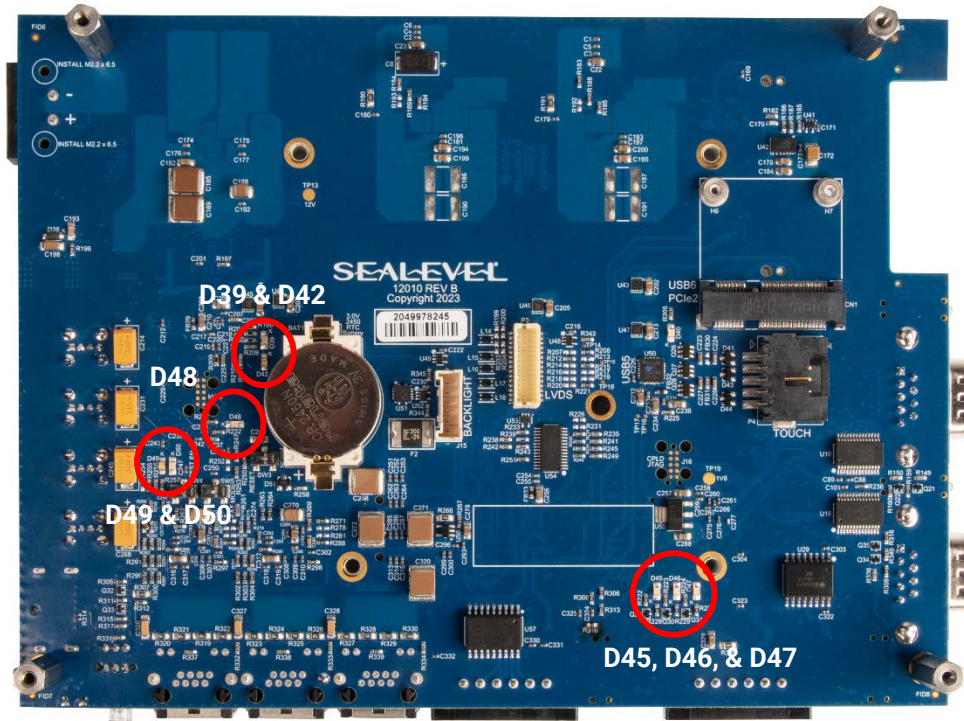

LED Locations on Bottom Side of Board

LED	Signal	Notes
D45, D46, D47	CPLD Heartbeat	Blink green to confirm heartbeat
D49, D50	MCU	MCU powered up
D42	Power Indicator	Solid green when powered on
D39	High Speed port indicator	Solid red when powered on
D48	3V3 MCU Status	Slow blink green to indicate good status

SWITCH (SW4) – TEST ENABLE

The switch (SW1) is used for manufacturing testing and debugging purposes. The switch is shipped in the Normal position and should not be changed in the field.

SWITCH (SW5) – AT MODE

The switch (SW2) is used for manufacturing testing and debugging purposes. The switch is shipped in the position that is NOT AT Mode and should not be changed in the field.

SWITCH (SW3) – RTC RESET

The switch (SW3) is used for manufacturing testing and debugging purposes. The switch is shipped in the NORMAL position. Moving the switch to RST (Reset) position will disconnect the battery from the COM Express module, thus clearing RTC/CMOS settings.

System Operation

Power States

The 12010 is designed to operate in four Power States as defined by ACPI.

S0 – Fully powered and operational

S3 – Suspended to memory (known as sleep in Windows)

S4 – Suspended to disk (known as Hibernate in Windows)

S5 – Powered down in standby (Windows Shutdown)

The system can transition from S0 to any of the three listed standby states (S3, S4, or S5) by either software command or an external Power Button (connected to Header P4). The system can then be awoken from either listed sleep/standby state by holding the Power Button for >1 second. The system can also be awoken from S3 or S4 with a USB input device such as a HID compliant keyboard or mouse.



For a USB device to be used to wake the computer, it must be present when the computer enters the sleep state and must remain connected for the duration of the sleep state.

External Power Button

An external power button can be used to turn the system on, shut the system down or place the computer in sleep states S3 or S4 (depending on OS support and configuration). The power button can also wake the system up from sleep states S3 or S4.

The power button has a one-second hardware debounce/delay built in to prevent an accidental shutdown. This delay is always present so the power button must be held for >1 second before system power up, power down, sleep or wake occurs.

Reset Button (BP1)

Beside the main power switch, the dual stage reset button provides two functions.

1. Holding the switch for at least 1 second and releasing within 5 seconds will perform a hard reset of the COM Express module only.
2. Holding the switch for at least 5 seconds and releasing will perform a full hardware reset of the entire system (CPU included).



Any momentary press of the switch for less than 1 second will be ignored.

Software Installation

At Sealevel Systems, we preinstall all required software needed for the 12010. If for some reason you need to reinstall any software or drivers, you can find what you need at the below links:

1. [SeaMAX - Windows Download](#)
2. [Software: SeaCOM - Windows - Sealevel](#)



The below link requires a free congatec account.

3. [congatec - TCA7 Software \(Intel HD Graphics Driver, Trusted Execution Engine, & Intel Chipset\)](#)

SeaMAX Application Suite

SeaMAX Overview

The SeaMAX Suite is a collection of configuration/diagnostic utilities and software libraries that enable rapid application development. The SeaMAX API, included in the SeaMAX Suite, provides a common API for Sealevel data acquisition devices. SeaMAX is designed to simplify application development by requiring a little knowledge of the underlying communication protocols of these devices and replacing low-level programming. SeaMAX is available in an unmanaged library and a wrapper library that provides an interface to the API from managed code.

The SeaMAX API documentation, installed with SeaMAX, explains the usage and API references, including function calls and enumerations. Sealevel digital and analog I/O modules supported by SeaMAX software are designed to work with third-party applications via the SeaMAX API. To help simplify application development, the complete API documentation and code samples are automatically installed with the SeaMAX Suite and can be found in Windows by clicking Start à All Programs à Sealevel SeaMAX à Documentation.

For convenience, Sealevel offers [SeaMAX API documentation](#) on our website.

SeaMAX Windows Installation

Launch the SeaMAX installation package and follow the instructions presented onscreen for your operating system. Once SeaMax software is installed on your host PC you can proceed with configuring your device. You will need the tools installed during the configuration process.



To install Sealevel software, you must log in as an administrator or have administrator privileges.

MaxSSD Configuration & Diagnostic Utility

The Sealevel Systems configuration utility, MaxSSD, is designed to simplify the installation, configuration, and diagnostics of Sealevel I/O modules, including the 12010 carrier board. MaxSSD is a Microsoft Windows application and has been tested with Microsoft Windows 10 operating system. On the prototype version of the 12010, the MaxSSD Windows utility is installed on the desktop.

MaxSSD Connection Tab

When you run the MaxSSD utility, it will default to the “Connection” tab. Under the Type drop-box, you can select Serial, SeaDAC Lite USB, or Ethernet. The digital I/O on the 12010 carrier board installs as a custom “SeaDAC Lite USB” device, so select this option. MaxSSD will automatically search for SeaDAC Lite devices and display any found on the right side of the window. Double click on the “SeaDAC Lite 0” device on the right side to connect to the I/O. The Device and Digital I/O tabs will appear after connecting.

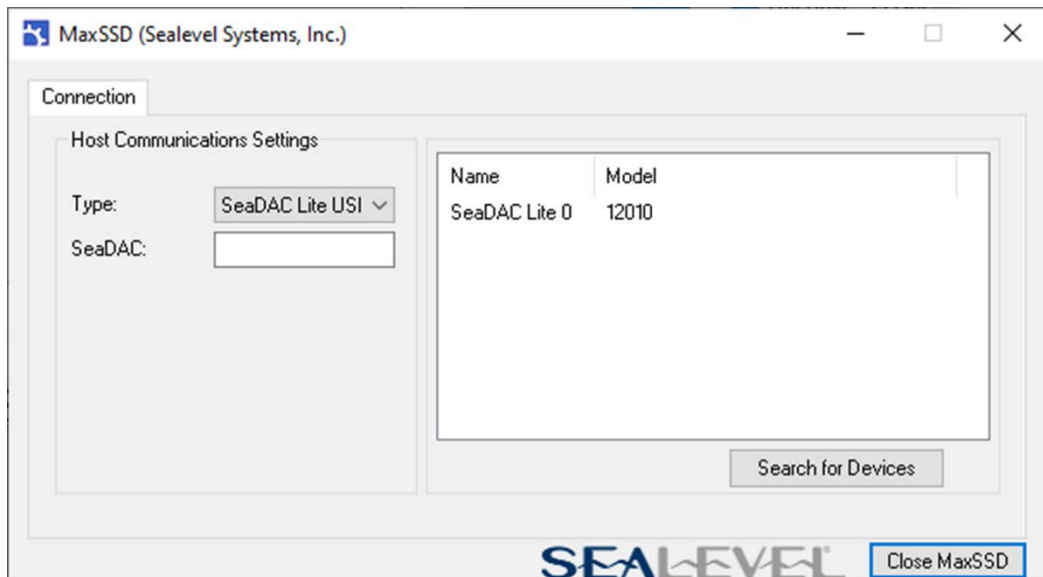
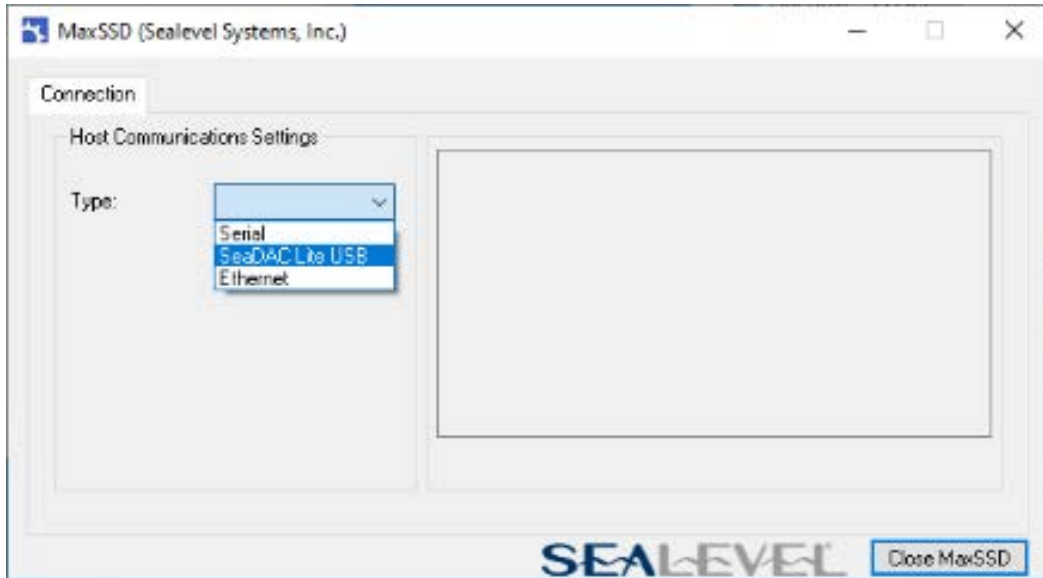

MaxSSD Device Tab

After you have selected the “SeaDAC Lite 0” device on the Connect tab, the Device and Digital I/O tabs will appear. MaxSSD will automatically change to the Device tab and display the relevant Device Description. The 12010 carrier board does not offer configurable communication settings.



MaxSSD Digital I/O Tab

Select the Digital I/O tab after you have successfully connected to the 12010 on the Connect tab. This tab displays the current input and output status in an intuitive and usable manner. Both inputs and outputs are displayed under Bank "1 - 2". The status LEDs will update automatically, allowing you to actively monitor external signals. The output relays can be triggered using the On/Off button below each output LED.

Test B report images

BIT 1



BIT 2

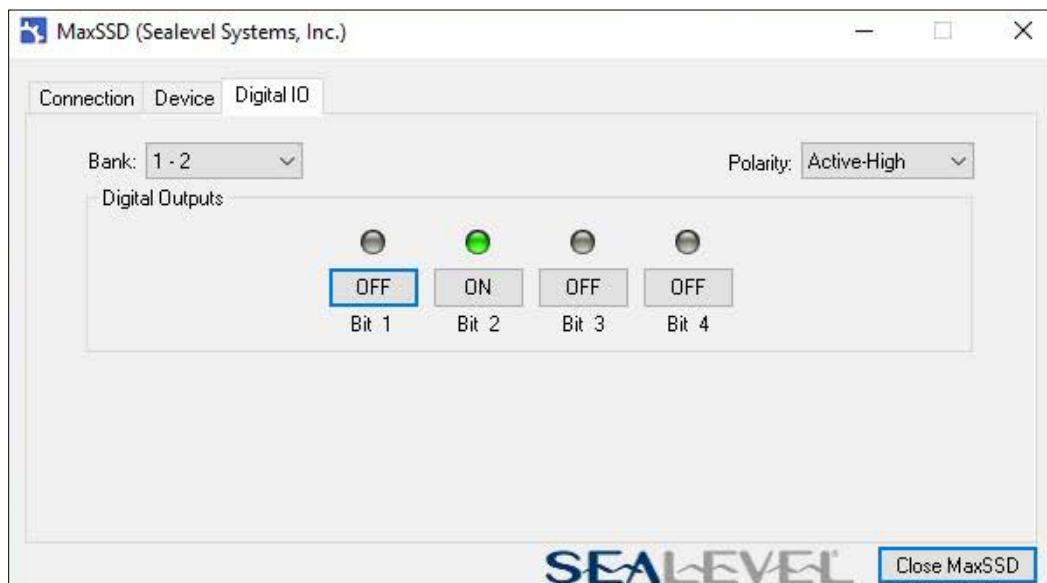

BIT 3



BIT 4



ALL BITS ON

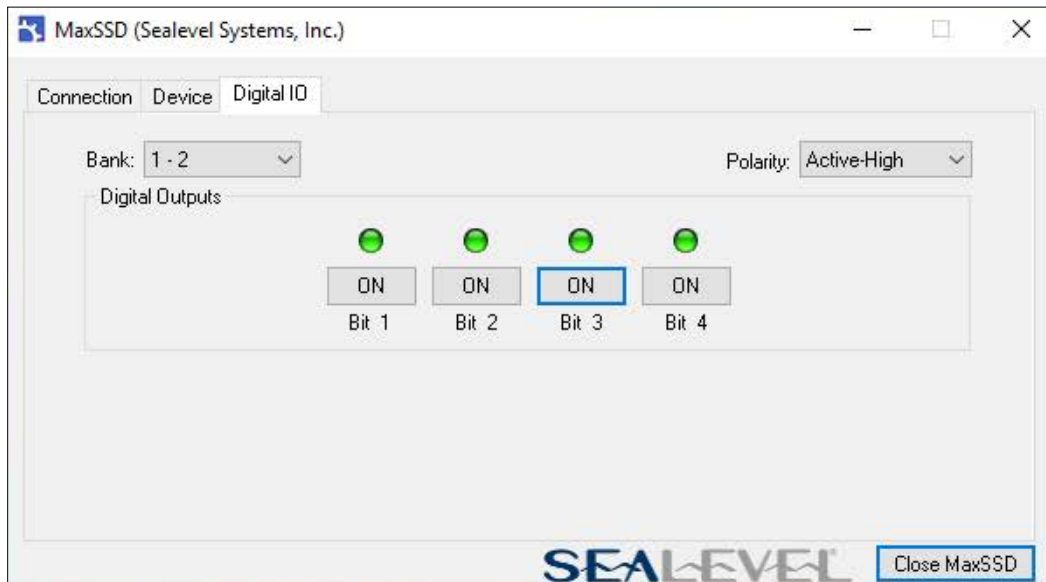

ALL BS OFF



Appendix A – Troubleshooting Serial Communication Issues

The serial port should provide years of trouble-free service. However, in the event that it appears to be functioning incorrectly, the following tips can eliminate most common problems without the need to call Technical Support.

Ensure that the Sealevel Systems SeaCOM software has been installed on the machine, so that the necessary files are in place to complete the installation. To confirm installation, click on the Windows 'Start' button and then select 'All Programs.' You should see the 'SeaCOM' program folder listed.

Check to make sure that USB support is enabled and functioning properly in the operating system. The presence of the 'Universal Serial Bus controllers' listing in Device Manager will confirm that USB support is enabled in Microsoft Windows 10 operating system.

While Device Manager is open, locate the COM ports (described under 'Verifying Installation' in the Installation and Configuration section of this manual).

Locate the COM ports for your device in Device Manager (described under 'Verifying Installation' in the Installation and Configuration section of this manual).

Troubleshooting/Verification for Asynchronous Serial Products

1. Once you have confirmed that the serial adapter COM ports are listed in Device Manager, use the Sealevel WinSSD utility to verify communications. Detailed help is included in the WinSSD utility.
2. If you have a loopback plug, put it on the adapter connector. If you do not have a loopback plug, you can use female jumper wires to make the connection to verify the functionality.
3. Connect pin number 2 (Receive) & 3 (Transmit) as shown in this graphic:

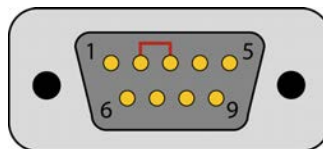

If you do not have a loopback plug or jumper wires handy, you can use a metal device, such as a knife, screwdriver, key, or paperclip, to short pins 2 and 3.

4. To test communications, launch the WinSSD utility in the SeaCOM folder in the 'Start' menu.
5. On the 'Port Information' tab, select the associated COM port and click the 'Open' button.
6. This will first open the COM port. From this tab the port can also be closed (See image below).
7. Click the 'Settings' button to open the COM Port Properties dialog box. This will allow the Port Settings to be altered.

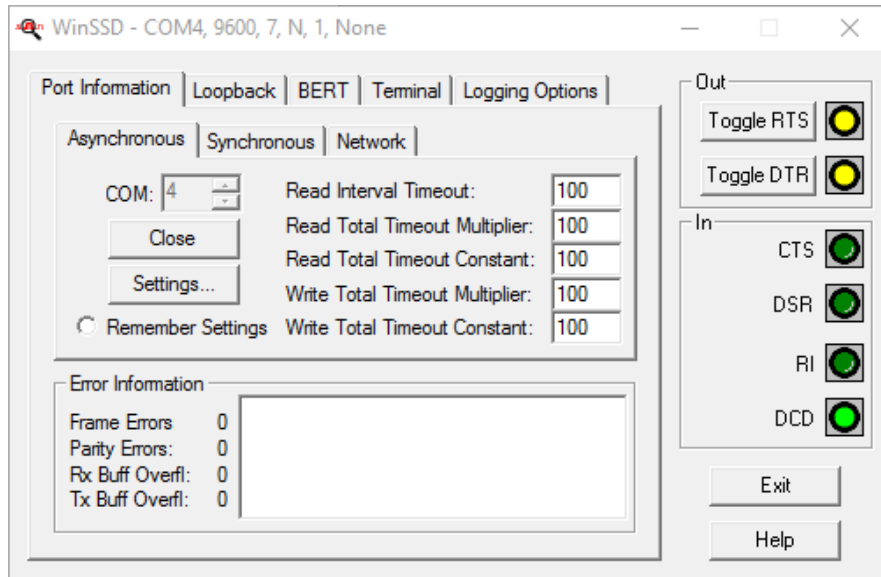

8. Change your parameters to 9600 bits per second, 8 data bits, no parity, 1 stop bit, and no flow control, as pictured below.

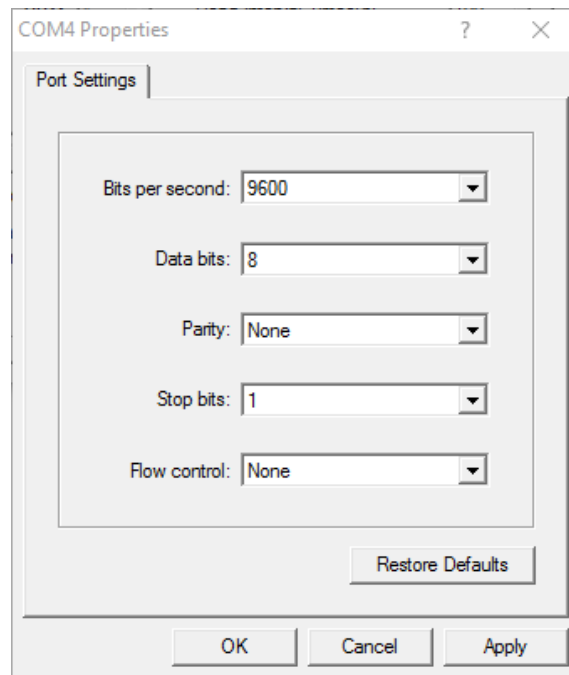

9. Click 'Apply' and 'OK'.
10. In the main WinSSD window, click on the 'BERT' tab (Bit Error Rate test).

11. Click on the 'Start' button.

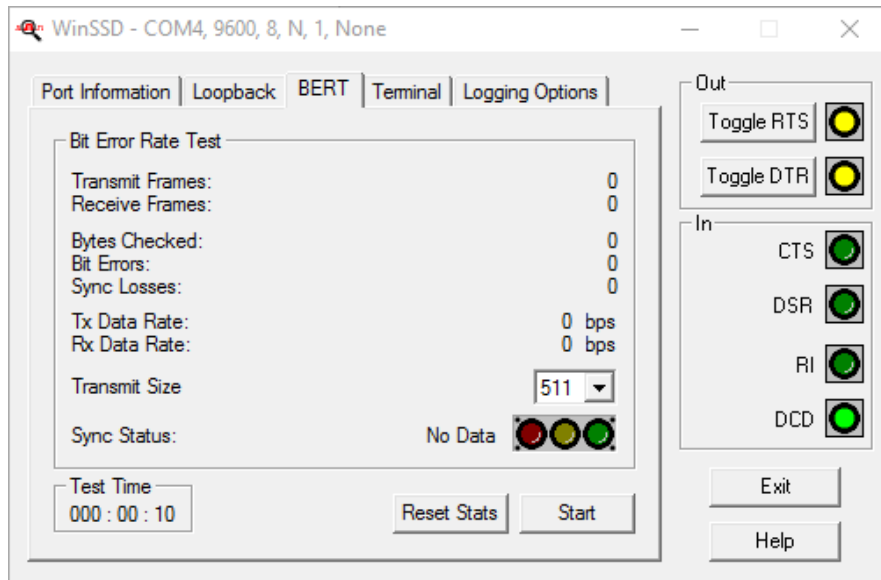

12. If the COM port is properly working, the Sync Status green light will glow, and the Transmit Frames and Receive Frames will increase. The Tx and Rx Data Rates will show the calculated data rate.

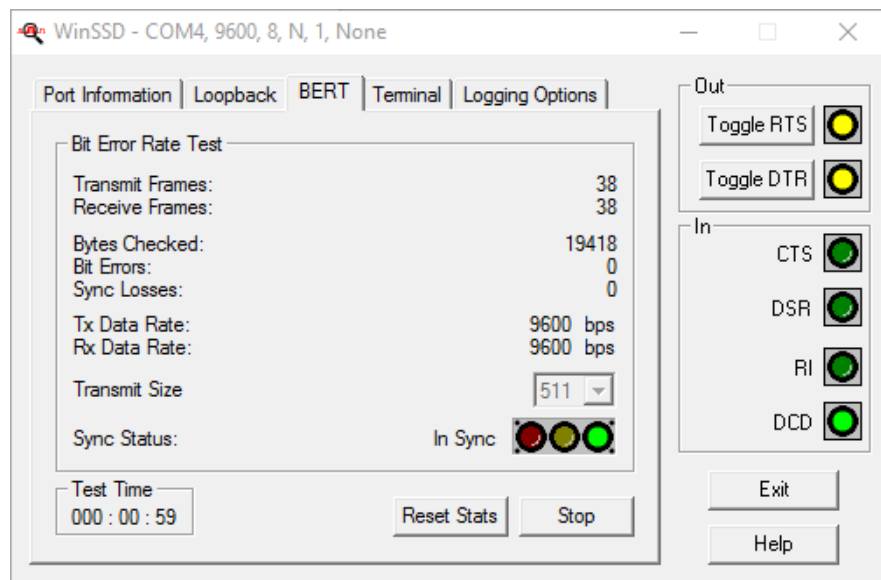

13. This verifies that the adapter is working properly. You can continue testing this port with different configurations or proceed with testing other ports, if necessary.

Appendix B – How To Get Assistance

Please refer to: [Appendix A](#) – Troubleshooting Guide prior to calling Technical Support.

1. Begin by reading the Trouble Shooting Guide in Appendix A. If assistance is still needed, please see below.
2. When calling for technical assistance, please have your user manual and current adapter settings. If possible, please have the adapter installed in a computer ready to run diagnostics.
3. Sealevel Systems provides an FAQ section on its web site. Please refer to this to answer many common questions. This section can be found at <http://www.sealevel.com/faq.asp>.
4. Sealevel Systems maintains a web page on the Internet. Our home page address is www.sealevel.com. The latest software updates, and newest manuals are available via our web site.
5. Technical support is available Monday to Friday from 8:00 AM to 5:00 PM Eastern Time. Technical support can be reached at (864) 843-4343 or support@sealevel.com.

RETURN AUTHORIZATION MUST BE OBTAINED FROM SEALEVEL SYSTEMS BEFORE RETURNED MERCHANDISE WILL BE ACCEPTED. AUTHORIZATION CAN BE OBTAINED BY CALLING SEALEVEL SYSTEMS AND REQUESTING A RETURN MERCHANDISE AUTHORIZATION (RMA) NUMBER.

Appendix C – Board Dimensions

12010 Top View

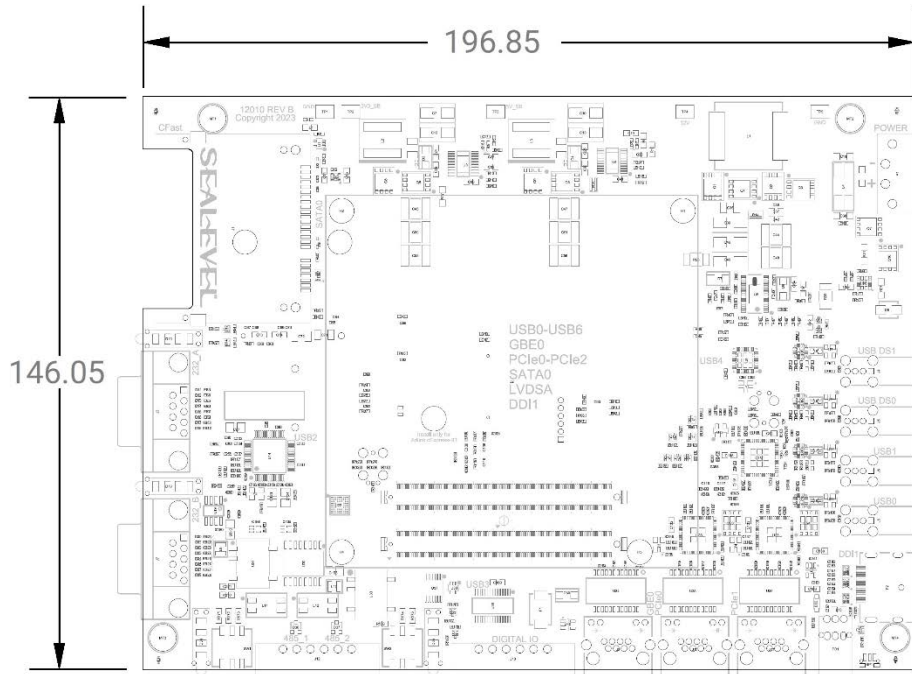

12010 Bottom View

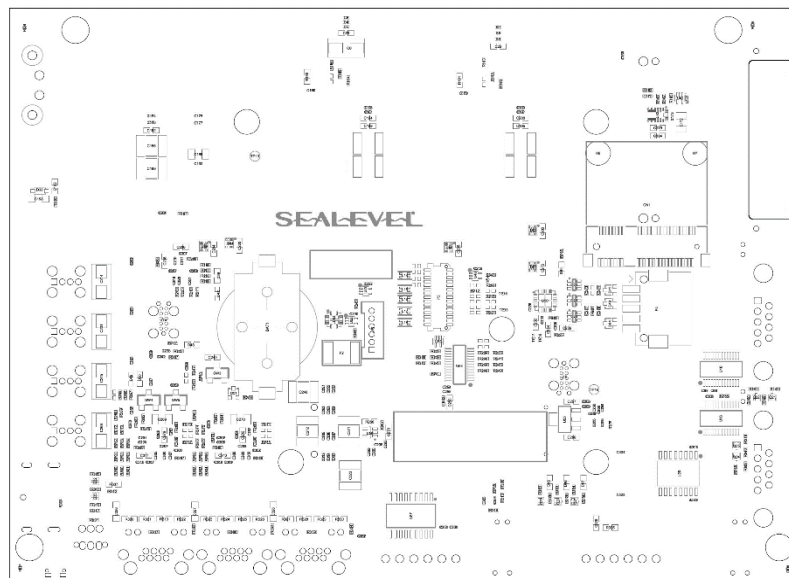

Appendix D – Handling Instructions

ESD Warning

ELECTROSTATIC DISCHARGES (ESD)

A sudden electrostatic discharge can destroy sensitive components. Proper packaging and grounding rules must therefore be observed. Always take the following precautions:

1. Transport boards and cards in electrostatically secure containers or bags.
2. Keep electrostatically sensitive components in their containers, until they arrive at an electrostatically protected workplace.
3. Only touch electrostatically sensitive components when you are properly grounded.
4. Store electrostatically sensitive components in protective packaging or on anti-static mats.

GROUNDING METHODS

The following measures help to avoid electrostatic damages to the device:

1. Cover workstations with approved antistatic material. Always wear a wrist strap connected to a properly grounded workplace.
2. Use antistatic mats, heel straps, and/or air ionizers for more protection.
3. Always handle electrostatically sensitive components by their edge or by their casing.
4. Avoid contact with pins, leads, or circuitry.
5. Turn off power and input signals before inserting and removing connectors or connecting test equipment.
6. Keep work area free of non-conductive materials such as ordinary plastic assembly aids and Styrofoam.
7. Use field service tools such as cutters, screwdrivers, and vacuum cleaners that are conductive.

Appendix E – Board Photos

Front I/O Connectors

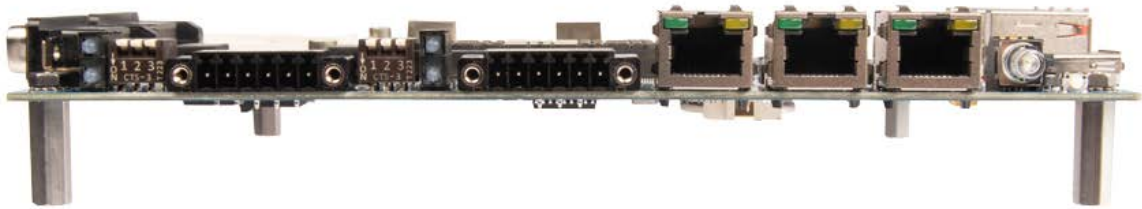

Side (Left) I/O Connectors

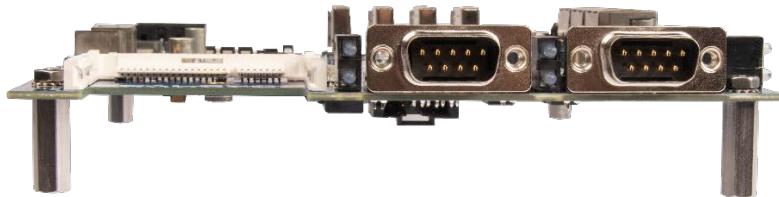

Side (Right) I/O Connectors - Need New Image

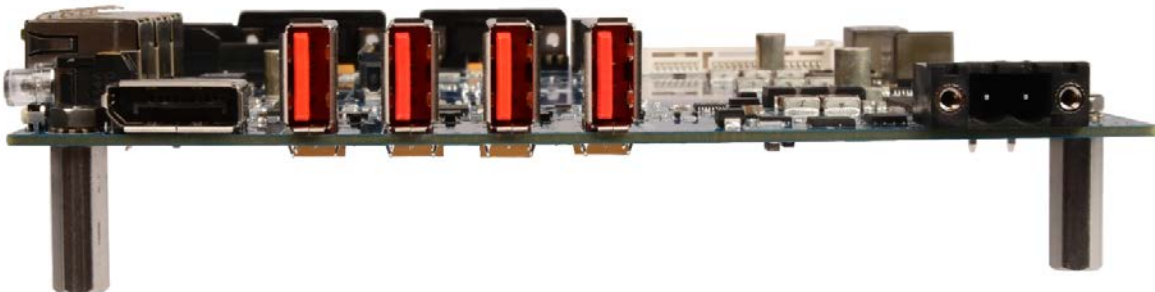

12010 Top View

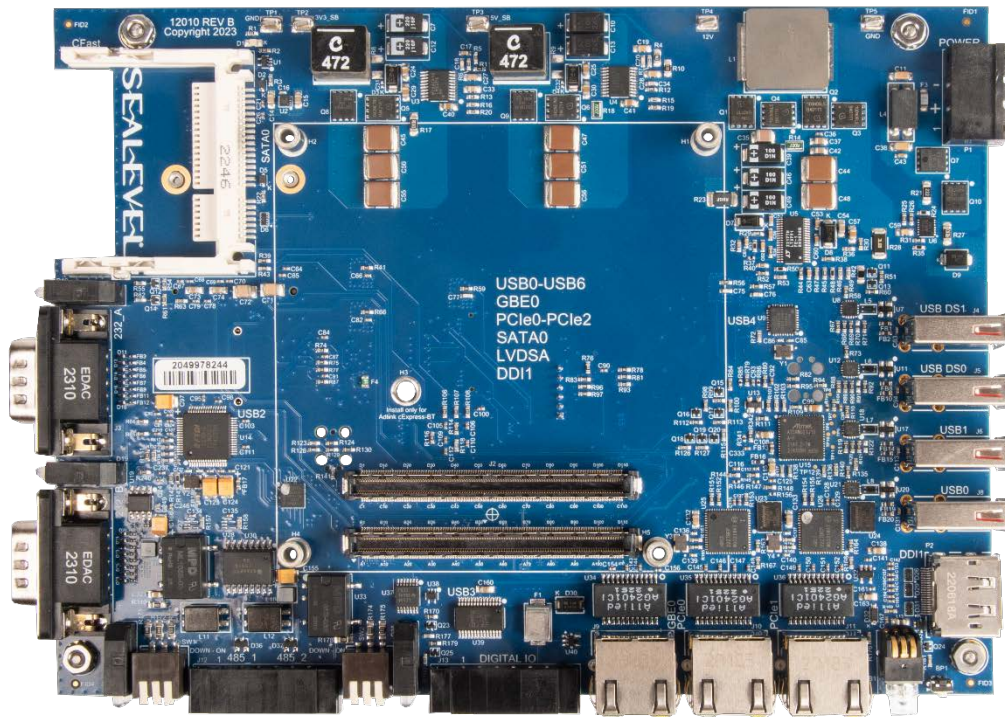

12010 Bottom View

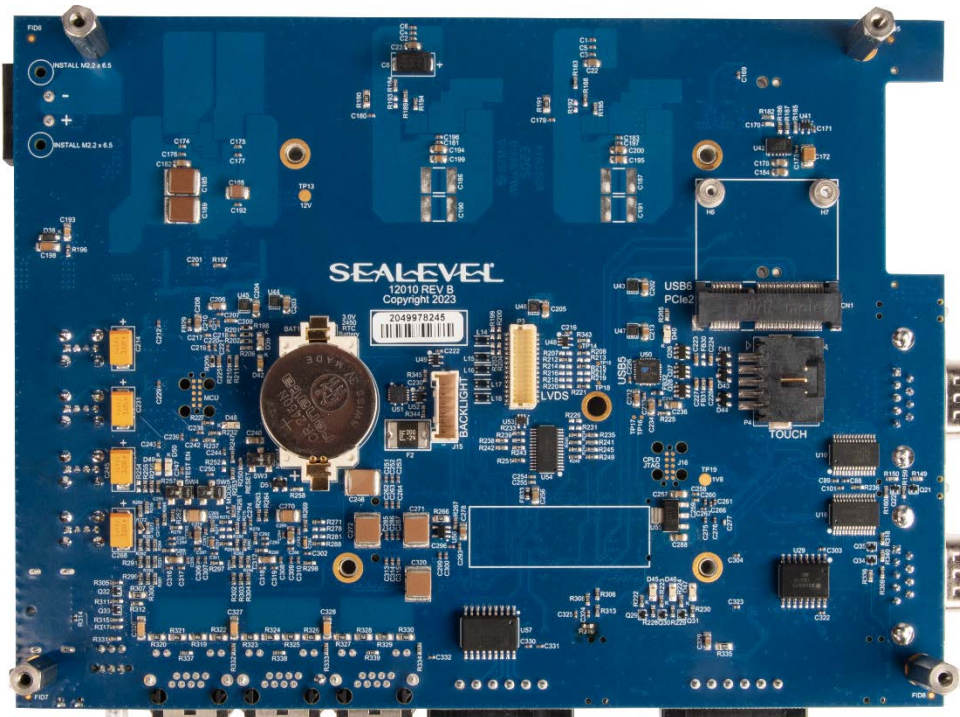

12010 Additional Views

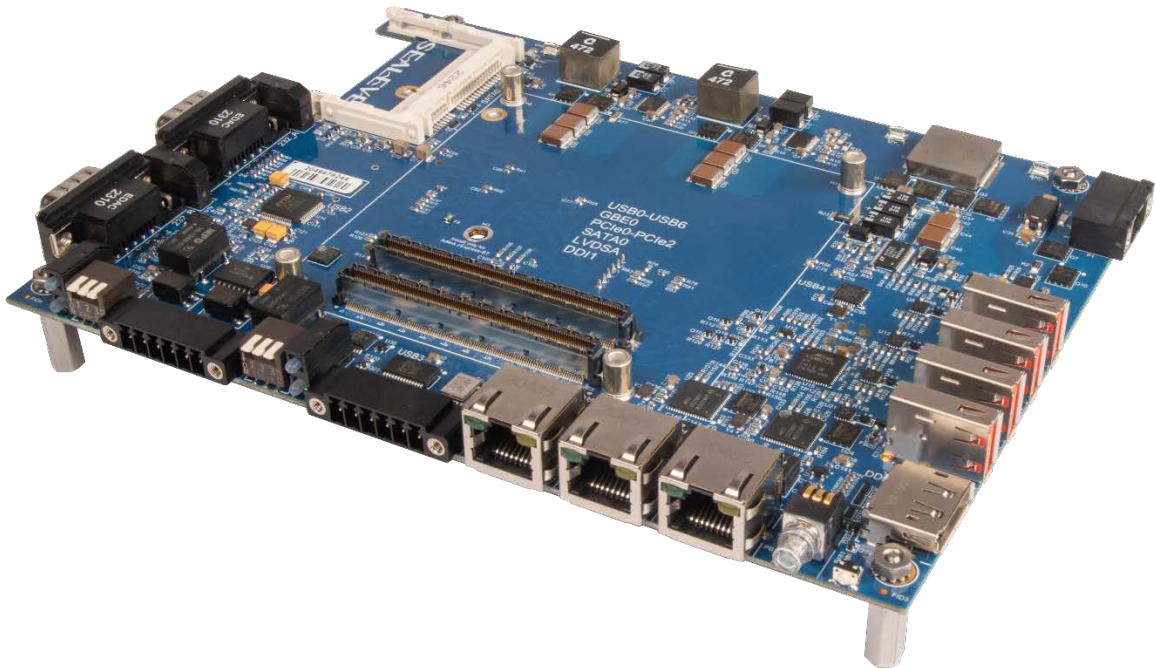
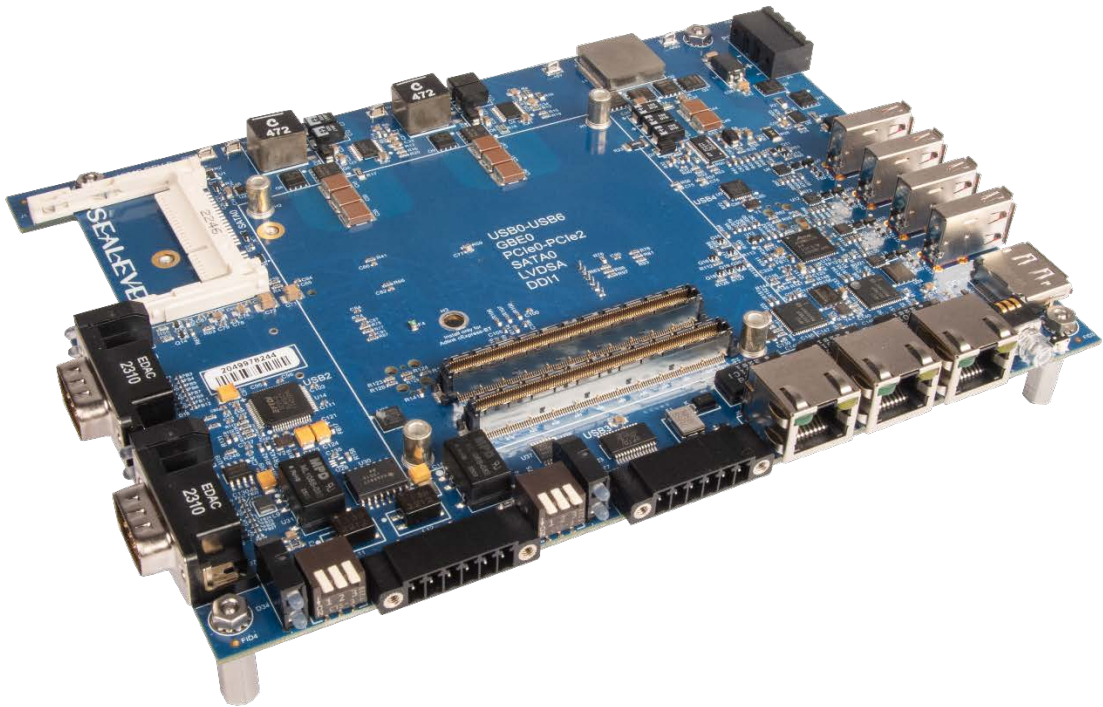

Appendix F – Compliance Notices

Federal Communications Commission (FCC) Statement



This equipment has been tested and found to comply with the limits for a Class A digital device, pursuant to part 15 of the FCC Rules. Operation is subject to the following two conditions: (1) This device may not cause harmful interference, and (2) this device must accept any interference received, including interference that may cause undesired operation.

These limits are designed to provide reasonable protection against harmful interference when the equipment is operated in a commercial environment. This equipment generates, uses, and can radiate radio frequency energy and, if not installed and used in accordance with the instruction manual, may cause harmful interference to radio communications. Operation of this equipment in a residential area is likely to cause harmful interference in such case the user will be required to correct the interference at the user's expense.



Always use the cabling provided with this product if possible. If no cable is provided or if an alternate cable is required, use high quality shielded cabling to maintain compliance with FCC/EMC directives.

UL 94V0

All Sealevel Systems Printed Circuit boards are built to UL 94V0 rating and are 100% electrically tested. These printed circuit boards are solder mask over bare copper or solder mask over tin nickel.

Warranty

Sealevel's commitment to providing the best I/O solutions is reflected in the Lifetime Warranty that is standard on all Sealevel manufactured I/O products. We are able to offer this warranty due to our control of manufacturing quality and the historically high reliability of our products in the field. Sealevel products are designed and manufactured at its Liberty, South Carolina facility, allowing direct control over product development, production, burn-in and testing. Sealevel achieved ISO-90012015 certification in 2018.

Warranty Policy

Sealevel Systems, Inc. (hereafter "Sealevel") warrants that the Product shall conform to and perform in accordance with published technical specifications and shall be free of defects in materials and workmanship for the warranty period. In the event of failure, Sealevel will repair or replace the product at Sealevel's sole discretion. Failures resulting from misapplication or misuse of the Product, failure to adhere to any specifications or instructions, or failure resulting from neglect, abuse, accidents, or acts of nature are not covered under this warranty.

Warranty service may be obtained by delivering the Product to Sealevel and providing proof of purchase. Customer agrees to insure the Product or assume the risk of loss or damage in transit, to prepay shipping charges to Sealevel, and to use the original shipping container or equivalent. The warranty is valid only for the original purchaser and is not transferable.

This warranty applies to Sealevel manufactured Product. Product purchased through Sealevel but manufactured by a third party will retain the original manufacturer's warranty.

Non-Warranty Repair/Retest

Products returned due to damage or misuse and Products retested with no problem found are subject to repair/retest charges. A purchase order or credit card number and authorization must be provided in order to obtain an RMA (Return Merchandise Authorization) number prior to returning the Product.

How to obtain an RMA (Return Merchandise Authorization)

If you need to return a product for warranty or non-warranty repair, you must first obtain an RMA number. Please contact Sealevel Systems, Inc. Technical Support for assistance:

Available	Monday – Friday, 8:00AM to 5:00PM EST
Phone	864-843-4343
Email	support@sealevel.com

Trademarks

Sealevel Systems, Incorporated acknowledges that all trademarks referenced in this manual are the service mark, trademark, or registered trademark of the respective company.