

# PIO-24.PCI

User Manual | 8008

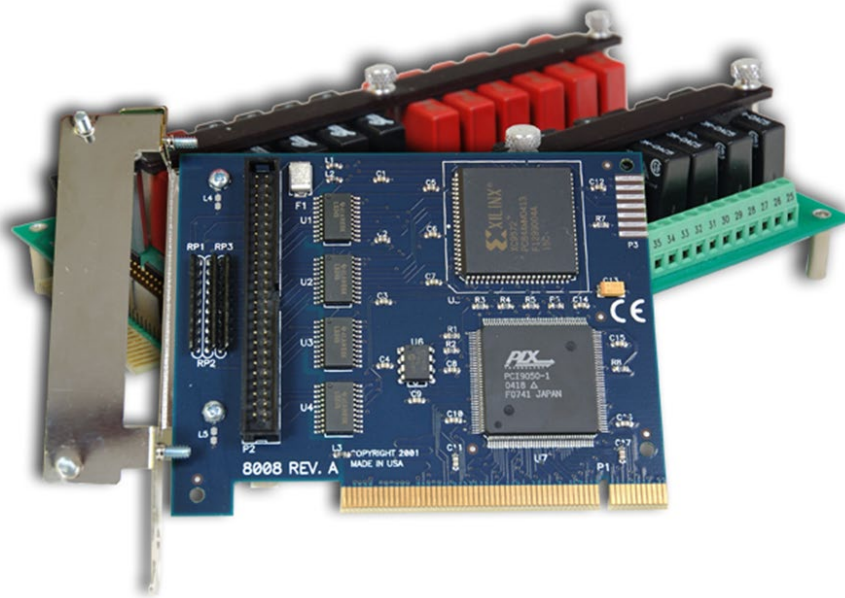

SEALEVEL®

# Contents

CONTENTS.....2

INTRODUCTION .....3

BEFORE YOU GET STARTED .....4

SOFTWARE INSTALLATION .....7

PHYSICAL INSTALLATION .....10

DIGITAL I/O INTERFACE.....11

PROGRAMMING THE PIO-24.PCI .....12

ELECTRICAL CHARACTERISTICS.....15

SPECIFICATIONS .....16

EXAMPLE CIRCUITS .....17

APPENDIX A – TROUBLESHOOTING.....18

APPENDIX B – HOW TO GET ASSISTANCE.....19

APPENDIX C – SILK SCREEN - 8008 PCB .....20

APPENDIX D – COMPLIANCE NOTICES .....21

WARRANTY .....22

# Introduction

The PIO-24.PCI, part number 8008, digital I/O interface provides 24 channels of buffered drive digital I/O emulating 8255 mode zero. The PIO-24.PCI can be utilized for a variety of control and automation applications including control and monitoring of TTL devices (e.g., LEDs, small solenoids, small relays) and interfacing to solid-state relay racks (SSRs) for high-power AC or DC loads.

The PIO-24.PCI's 24 digital I/O channels are accessed via a 50-pin header connector with industry-standard pin out. The header provides 24 bits of digital I/O divided into three eight-bit groups. Each eight-bit group may be individually configured via software command as input or output to best match your particular application requirements.

The PIO-24.PCI is designed to be used with a variety of Operating Systems including Windows, Linux, and DOS. The Seal/O API (Application Programmer Interface) available on Sealevel's website provides a variety of useful high-level function calls implemented as a Windows dynamic link library (DLL) and as a Linux kernel module and library. In addition to the API, Seal/O includes sample code and utilities to simplify software development.

## Other Sealevel PCI Digital I/O Products

Model No.	Part No.	Description
PIO-32.PCI	(P/N 8010)	- 32 TTL Inputs/Outputs
PIO-48.PCI	(P/N 8005)	- 48 TTL Inputs/Outputs
PIO-96.PCI	(P/N 8009)	- 96 TTL Inputs/Outputs
DIO-16.PCI	(P/N 8002)	- 8 Reed Relay Outputs/8 Opto-isolated Inputs
REL-16.PCI	(P/N 8003)	- 16 Reed Relay Outputs
DIO-32.PCI	(P/N 8004)	- 16 Reed Relay Outputs/16 Opto-isolated Inputs
ISO-16.PCI	(P/N 8006)	- 16 Opto-isolated Inputs
REL-32.PCI	(P/N 8007)	- 32 Reed Relay Outputs
PLC-16.PCI	(P/N 8011)	- 8 Form C Relay Outputs/ 8 Opto-isolated Inputs

# Before You Get Started

## What's Included

The PIO-24.PCI is shipped with the following items. If any of these items are missing or damaged, please contact Sealevel for replacement.

- **PIO-24.PCI Adapter**

## Advisory Conventions



### **Warning**

The highest level of importance used to stress a condition where damage could result to the product, or the user could suffer serious injury.



### **Important**

The middle level of importance used to highlight information that might not seem obvious or a situation that could cause the product to fail.



### **Note**

The lowest level of importance used to provide background information, additional tips, or other non-critical facts that will not affect the use of the product.

## Optional Items

Depending upon your application, you are likely to find one or more of the following items useful for interfacing the PIO-24.PCI to real-world signals. All items can be purchased from our website (<http://www.sealevel.com>) or by calling (864) 843-4343.

### For TTL Applications

- **Terminal Block Kit - (Part Number KT107)**

Kit includes the TB07 screw terminal block and CA167 ribbon cable for connecting the PIO-24.PCI's 50-pin header connector to your I/O. 6" Snap track and DIN rail clips are included for DIN rail mounting.

- **IDC 50 to IDC 50 Pin 40" Ribbon Cable (Part Number CA167)**

Interfaces the PIO-24.PCI's 50-pin header connector to your I/O.

- **Simulation/debug module (Part Number TA01)**

Module allows monitoring status of output pins and controlling state of input pins. An LED corresponding to each port bit illuminates to indicate state. Eight position DIP-switches are used to generate input status changes.

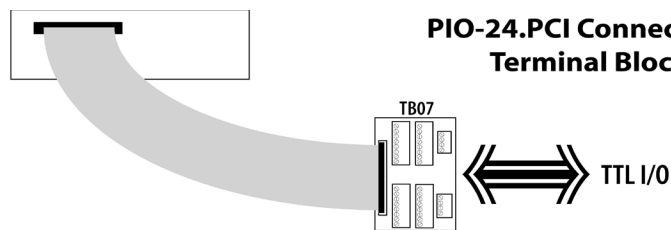

### For High-Current, High-Voltage Applications

- **IDC 50 to IDC 50 Pin Ribbon Cable (Part Number CA167)**

40" cable connects the PIO-24.PCI to solid-state relay racks equipped with a 50-pin header interface.

- **IDC 50 to IDC 50 Pin Ribbon Cable (Part Number CA135)**

40" cable connects the PIO-24.PCI to solid-state relay racks equipped with 50-pin edge connector.

## Optional Items, Continued

- **Solid State Relay Racks:**
  - **Quad six position relay rack (Part Number PB24HQ)**  
Relay rack can accept up to six QSSRs for a total of 24 channels. Features a 50-pin header connector for easy interface via 50-conductor ribbon cables.
  - **Quad four position relay rack (Part Number PB16HQ)**  
Relay rack can accept up to four QSSRs for a total of 16 channels. Features a 50-pin header connector for easy interface via 50-conductor ribbon cables.
- **Quad Solid State Relay Modules:**
  - **AC Input (Part Number IA5Q)**  
Provides 4 channels of discrete I/O interface to monitor AC inputs up to 140V @ 10mA.
  - **DC Input (Part Number IB5Q)**  
Provides 4 channels of discrete I/O interface to monitor DC inputs from 3.3V to 32V.
  - **AC Output (Part Number OA5Q)**  
Provides 4 channels of discrete I/O interface to control AC outputs up to 140V @ 3A.
  - **DC Output (Part Number OB5Q)**  
Provides 4 channels of discrete I/O interface to control DC outputs up to 60V @ 3A.
- **Simulation/debug module (Part Number TA01)**

Module simulates the operation and load characteristics of a standard 24-channel relay rack. An LED corresponding to each port bit illuminates to indicate state. Eight position DIP-switches are used to generate input status changes.

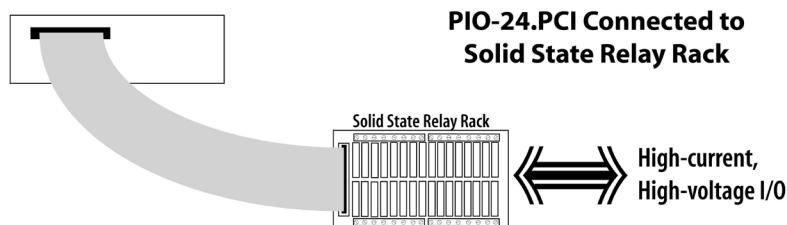

# Software Installation

## Windows Installation



Do not install the Adapter in the machine until the software has been fully installed.



Only users running Windows 7 or newer should utilize these instructions for accessing and installing the appropriate driver via Sealevel's website. If you are utilizing an operating system prior to Windows 7, please contact Sealevel by calling 864.843.4343 or emailing [support@sealevel.com](mailto:support@sealevel.com) to receive access to the legacy driver download and installation instructions.

1. Select the download for the SealO Classic for Windows ([Software: SealO Classic V5 - Windows - Sealevel.](#)) The setup file will automatically detect the operating environment and install the proper components. Next (depending on your browser) select the 'Run this program from its current location' or 'Open' option. Follow the information presented on the screens that follow. During setup, the user may specify installation directories and other preferred configurations. This program also adds entries to the system registry that are necessary for specifying the operating parameters for each driver. An uninstall option is also available to remove SealO files and registry/INI file entries from the system.
2. If installing in NT, skip to step 11. 'Windows NT Card Installation.'
3. Go to the "Add New Hardware Wizard" in the Control Panel.
4. When the Wizard asks if you want Windows to search for the new hardware, choose "No, I want to select the hardware from a list."
5. Scroll through the list of categorized hardware and select 'SealO Devices.' If this is the first SealO device you may need to select 'Other Devices' and 'Sealevel Systems, Inc.' instead of 'SealO Devices.'
6. Click "Next."
7. Select the card model and press "Next."
8. The Wizard will guide you through a few more informational prompts; continue to click "Next" until it is completed.
9. Your card's resource assignments may be adjusted through the Device Manager (if, for instance, you need to change the I/O port address Windows assigned when you installed the card).
10. Windows software installation is complete

## Windows Installation, Continued

11. Windows NT Card Installation: After accomplishing steps 1, bring up the Control Panel and double-click on the SealIO Devices icon. To install a new card, click "Add Port." Repeat this procedure for as many SealIO cards as you wish to install.

## Linux Installation



You MUST have "root" privileges to install the software and drivers.



The syntax is case sensitive.



Users can obtain a README file included in the SealIO Linux package which contains important installation and configuration instructions that makes the Linux installation more user friendly.

1. Login as "root"
2. Select download for the version of SealIO Classic for Linux ([Software: SealIO Classic - Linux - Sealevel.](#))

3. Copy seaio.tar.gz to your home directory by typing:

```
cp seaio.tar.gz ~
```

4. Change to your home directory by typing:

```
cd
```

5. Unzip and Untar the drivers and software by typing:

```
tar -xvzf seaio.tar.gz
```

6. Change to the SealIO directory by typing:

```
cd seaio
```

7. User must download and compile a Linux kernel source.

8. Now compile and prepare the drivers for use by typing:

```
make install
```

9. Using your favorite text editor, edit the /etc/seaio.conf

10. Within the quote marks, insert

```
cardtype=0xYourSealOcardType io=0xCardBaseAddress
```



## Linux Installation, Continued



YourSealOcardType = Model Number of your SealO Card.  
CardBaseAddress = What base address you have your SealO card addressed at.

11. Save the file and exit your editor.
12. With the system off and unplugged, install your SealO PCI card.
13. Plug system back in and boot Linux. Login as "**root**".
14. Load the SealO driver by typing:

**seaioload**

15. The driver has enabled the card and is ready to use.

To set up Linux to automatically load the driver; refer to a Linux manual concerning your specific distribution for help.

For additional software support, please call Sealevel Systems' Technical Support, (864) 843-4343. Our technical support is free and available from 8:00 AM - 5:00 PM Eastern Time, Monday through Friday. For email support contact: [support@sealevel.com](mailto:support@sealevel.com).

# Physical Installation

The adapter can be installed in any 5V PCI expansion slot.



Do not install the Adapter in the machine until the software has been fully installed.

1. **Turn off PC power. Disconnect the power cord.**
2. Remove the PC case cover.
3. Locate an available 5V PCI slot and remove the blank metal slot cover.
4. Gently insert the PCI adapter into the slot. Make sure that the adapter is seated properly.
5. After the adapter has been installed, the cables should be routed thru the opening in the bracket. This bracket also features a strain relief function that should be used to prevent un-expected cable removal.
6. Replace the screw you removed for the blank and use it to secure the adapter into the slot. (This is required to ensure FCC Part 15 compliance.)
7. Replace the cover.
8. Connect the power cord

The PIO-24.PCI is now ready for use.

# Digital I/O Interface

The PIO-24.PCI's 24 digital I/O channels are accessed via an industry-standard 50-pin header connector. The header provides 24 bits of digital I/O divided into three eight-bit ports. Each port may be individually configured via software command as input or output.

## 50-pin Header Connector

You will need to install the bracket assembly and cable to the PIO-24.PCI prior to installing it in the PC. The PIO-24.PCI's bracket features a unique cable clamp that provides a solid strain relief to prevent inadvertent cable removal.

The 50-pin connector has the following pin out which is compatible with a wide variety of solid state relay racks:

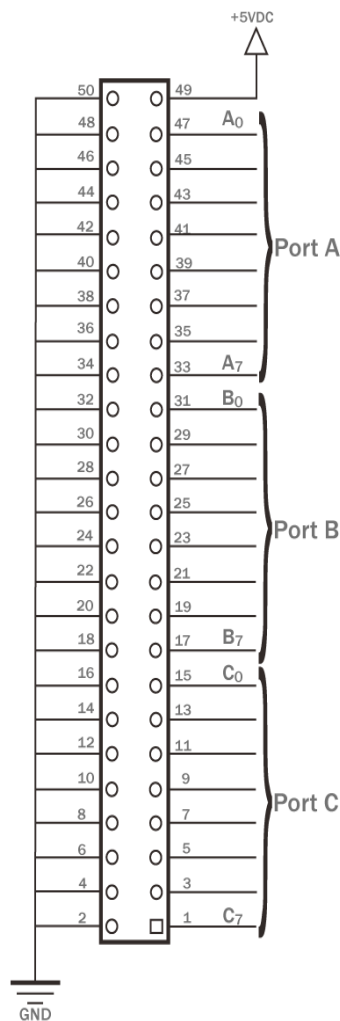

# Programming the PIO-24.PCI

Sealevel's Seal/O software is provided to assist in the development of reliable applications for the Sealevel Systems family of digital I/O adapters. Included on the Seal/O CD are driver functions for use in accessing the I/O as well as helpful samples and utilities.

## Programming for Windows

The Seal/O API (Application Programmer Interface) provides a variety of useful high-level function calls implemented in a Windows dynamic link library (DLL). The API is defined in the help file (Start/Programs/SealO/SealO Help) under "Application Programmers Interface." This help file also includes detailed information dealing with installation / removal of the software and information about latency, logic states, and device configuration.

For C language programmers we recommend using the API to access the PIO-24.PCI. If you are programming in Visual Basic, using the ActiveX control included with Seal/O is advised.

## Samples and Utilities

A variety of sample programs and utilities (both executable and source code) are included with Seal/O. Further documentation on these samples can be found by selecting "Start/Programs/SealO/Sample Application Description." Information about where the files are physically stored on your disk is also included in this same file.

## Programming for Linux

Seal/O for Linux consists of two major parts: a kernel module and a library. The kernel module is a simple IO pass-through device, allowing the library to handle the more sophisticated functions provided to Seal/O users. It is provided in a 'tarball' format and can easily be compiled and included in the kernel build.

## Direct Hardware Control

In systems where the users program has direct access to the hardware (DOS) the tables that follow give the mapping and functions that the PIO-24.PCI provides.

## Reading the Inputs

The inputs are active true. If an input is driven high (2V to 5.25 V) it will read as a logical one, if driven low (0V to 0.8V) it will read as a logical zero. If an input is not driven it will read as a one due to the 10K ohm pull up resistors on each port.

## Reading the Outputs

The value that is currently being used to drive the outputs will be returned.

## Presetting an Output Port

Each port has an output register associated with it. This register may be written and retains its value whether the port is configured as an input or an output. To preset the value of an output port the program should write to the port when it is configured as an input then configure it as an output.

## Writing the Outputs

The outputs are active true. Writing a one (1) corresponds to 5V while writing a zero (0) corresponds to 0V, at the output.

## Register Description

Address		Mode	D7	D6	D5	D4	D3	D2	D1	D0
Base+0	Port A1	RD/WR	PA1D7	PA1D6	PA1D5	PA1D4	PA1D3	PA1D2	PA1D1	PA1D0
Base+1	Port B1	RD/WR	PB1D7	PB1D6	PB1D5	PB1D4	PB1D3	PB1D2	PB1D1	PB1D0
Base+2	Port C1	RD/WR	PC1D7	PC1D6	PC1D5	PC1D4	PC1D3	PC1D2	PC1D1	PC1D0
Base+3	CW Port 1	WR	CW1D7	0	0	CW1D4	CW1D3	CW1D2	CW1D1	CW1D0
Base+4	Interrupt Port 1	RD/WR	0	0	0	0	0	IRQEN1	IRQC11	IRQC10
Base+5	IntStat Port 1	RD	0	0	0	0	0	0	0	IRQST1

IntStat = Interrupt Status

## I/O Control Word

Each port may be configured as either Input or Output. This is accomplished by writing the correct Control Word (CW) to the proper register.

Control Word (X = 0)								Hex Value	Port Setup			
7	6	5	4	3	2	1	0		A	B	C Upper	C Lower
1	X	X	0	0	X	0	0	80	Out	Out	Out	Out
1	X	X	0	0	X	0	1	81	Out	Out	Out	In
1	X	X	0	0	X	1	0	82	Out	In	Out	Out
1	X	X	0	0	X	1	1	83	Out	In	Out	In
1	X	X	0	1	X	0	0	88	Out	Out	In	Out
1	X	X	0	1	X	0	1	89	Out	Out	In	In
1	X	X	0	1	X	1	0	8A	Out	In	In	Out
1	X	X	0	1	X	1	1	8B	Out	In	In	In
1	X	X	1	0	X	0	0	90	In	Out	Out	Out
1	X	X	1	0	X	0	1	91	In	Out	Out	In
1	X	X	1	0	X	1	0	92	In	In	Out	Out
1	X	X	1	0	X	1	1	93	In	In	Out	In
1	X	X	1	1	X	0	0	98	In	Out	In	Out
1	X	X	1	1	X	0	1	99	In	Out	In	In
1	X	X	1	1	X	1	0	9A	In	In	In	Out
1	X	X	1	1	X	1	1	9B	In	In	In	In

## Interrupt Control

When enabled interrupts are generated on port bit D0 of each A port.

n = port number

IRQENn	interrupt enable	1 = enabled	0 = disabled ( 0 on power up )
IRQn0	Interrupt mode select, see table below		
IRQn1	Interrupt mode select, see table below		

## Interrupt Mode Select Table

IRQn1	IRQn0	INT Type
0	0	Low level
0	1	High level
1	0	Falling edge
1	1	Rising edge

## Interrupt Read

Reading the INTSTAT port (Base+5) clears any interrupt pending.

IRQST1	(D0) Interrupt status	1 = interrupt pending, 0 = none
--------	-----------------------	---------------------------------

# Electrical Characteristics

The PIO-24.PCI uses 74LS245 octal bi-directional transceivers to provide TTL input/output capabilities. Each bit is pulled to +5V through a 10K ohm pull-up resistor to insure each bit is at a known state when not driven.

Input Circuit Schematic

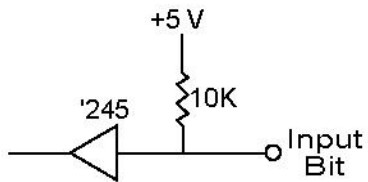

Output Circuit Schematic

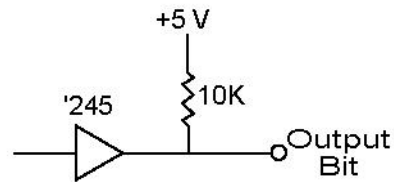

# Specifications

## Inputs

Logic High	Min 2VDC
Logic Low	Max 0.8VDC

## Outputs

Logic High	Min 2VDC @ 15 mA
Logic Low	Max 0.5VDC @ 24 mA

## Temperature Range

Operating	0°C - 70°C
Storage	-50°C - 105°C

## Power Requirements

Supply line	+5 VDC
Rating	1A



# Example Circuits

### TTL Input

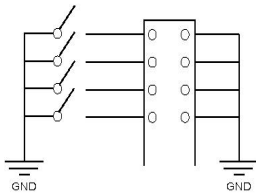

### TTL Output

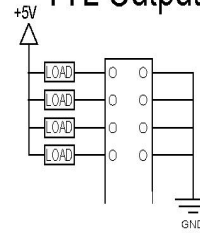

### Solid State Relay Input

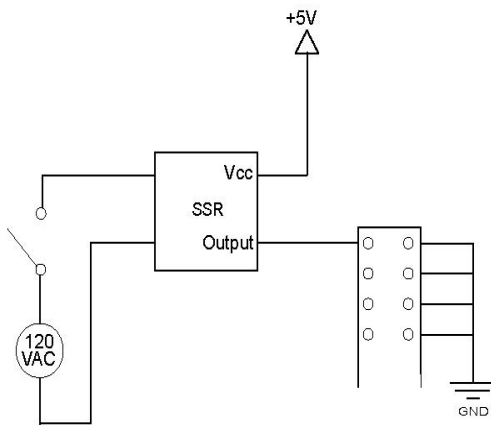

### Solid State Relay Output

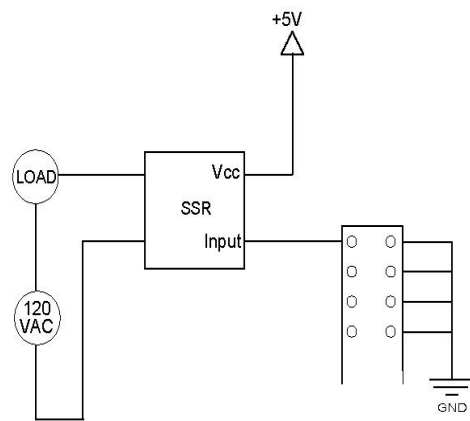

# Appendix A – Troubleshooting

The adapter should provide years of trouble-free service. However, in the event that device appears to not be functioning incorrectly, the following tips can eliminate most common problems without the need to call Technical Support.

1. Read this manual thoroughly before attempting to install the adapter in your system.
2. Use Device Manager under Windows to verify proper installation.
3. Use the Seal/O control panel applet for card identification and configuration.
4. Identify all I/O adapters currently installed in your system. This includes your on-board serial ports, controller cards, sound cards etc. The I/O addresses used by these adapters, as well as the IRQ (if any) should be identified.
5. Configure your Sealevel Systems adapter so that there is no conflict with currently installed adapters. No two adapters can occupy the same I/O address.
6. Make sure the Sealevel Systems adapter is using a unique IRQ The IRQ is typically selected via an on-board header block. Refer to the section on Card Setup for help in choosing an I/O address and IRQ.
7. Make sure the Sealevel Systems adapter is securely installed in a motherboard slot.
8. If you are utilizing an operating system prior to Windows 7, please contact Sealevel's Technical support as directed below to receive more information regarding the utility software which will determine if your product is functioning properly.
9. Only users running Windows 7 or newer should utilize the diagnostic tool '[WinSSD](#)' installed in the SeaCOM folder on the Start Menu during the setup process. First find the ports using the Device Manager, then use 'WinSSD' to verify that the ports are functional.
10. Always use the Sealevel Systems diagnostic software when troubleshooting a problem. This will help eliminate any software issues and identify any hardware conflicts.

If these steps do not solve your problem, please call Sealevel Systems' Technical Support, (864) 843-4343. Our technical support is free and available from 8:00 A.M.- 5:00 P.M. Eastern Time Monday through Friday. For email support contact [support@sealevel.com](mailto:support@sealevel.com).

# Appendix B – How To Get Assistance

Please refer to Troubleshooting Guide prior to calling Technical Support.

1. Begin by reading through the Trouble Shooting Guide in [Appendix A](#). If assistance is still needed please see below.
2. When calling for technical assistance, please have your user manual and current adapter settings. If possible, please have the adapter installed in a computer ready to run diagnostics.
3. Sealevel Systems provides an FAQ section on its web site. Please refer to this to answer many common questions. This section can be found at <http://www.sealevel.com/faq.asp>.
4. Sealevel Systems maintains a web page on the Internet. Our home page address is <https://www.sealevel.com/>. The latest software updates, and newest manuals are available via our web site.
5. Technical support is available Monday to Friday from 8:00 A.M. to 5:00 P.M. Eastern Time. Technical support can be reached at (864) 843-4343.

**RETURN AUTHORIZATION MUST BE OBTAINED FROM SEALEVEL SYSTEMS BEFORE RETURNED MERCHANDISE WILL BE ACCEPTED. AUTHORIZATION CAN BE OBTAINED BY CALLING SEALEVEL SYSTEMS AND REQUESTING A RETURN MERCHANDISE AUTHORIZATION (RMA) NUMBER.**

# Appendix C – Silk Screen - 8008 PCB

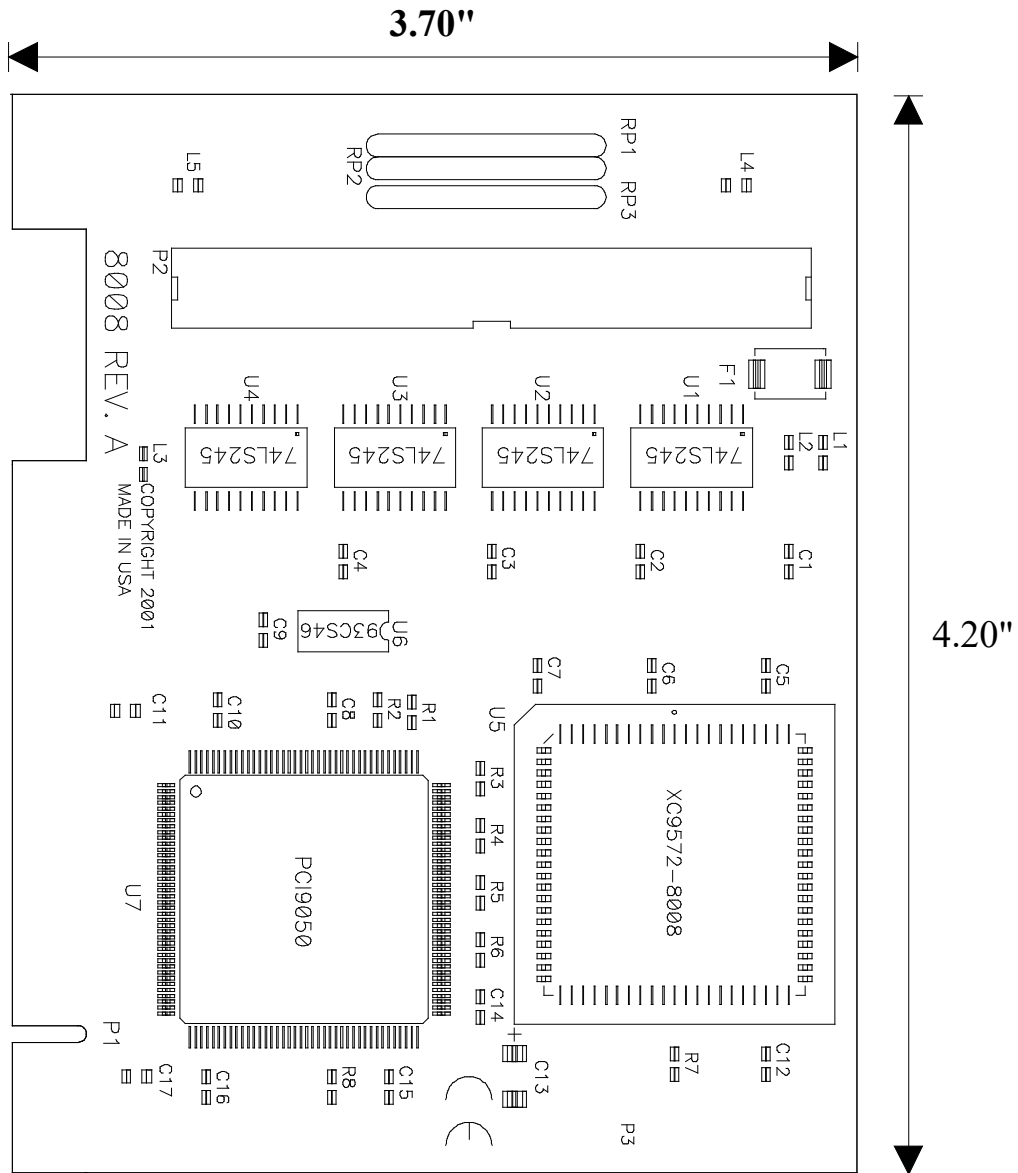

# Appendix D – Compliance Notices

## Federal Communications Commission (FCC) Statement



This equipment has been tested and found to comply with the limits for Class A digital device, pursuant to Part 15 of the FCC Rules. These limits are designed to provide reasonable protection against harmful interference when the equipment is operated in a commercial environment. This equipment generates, uses, and can radiate radio frequency energy and, if not installed and used in accordance with the instruction manual, may cause harmful interference to radio communications. Operation of this equipment in a residential area is likely to cause harmful interference in such case the user will be required to correct the interference at the users expense.

## EMC Directive Statement



Products bearing the CE Label fulfill the requirements of the EMC directive (89/336/EEC) and of the low-voltage directive (73/23/EEC) issued by the European Commission. To obey these directives, the following European standards must be met:

- **EN55022 Class A** - "Limits and methods of measurement of radio interference characteristics of information technology equipment"
- **EN55024** - "Information technology equipment Immunity characteristics Limits and methods of measurement".



This is a Class A Product. In a domestic environment, this product may cause radio interference in which case the user may be required to take adequate measures to prevent or correct the interference.



Always use cabling provided with this product if possible. If no cable is provided or if an alternate cable is required, use high quality shielded cabling to maintain compliance with FCC/EMC directives.

# Warranty

Sealevel's commitment to providing the best I/O solutions is reflected in the Lifetime Warranty that is standard on all Sealevel manufactured I/O products. We are able to offer this warranty due to our control of manufacturing quality and the historically high reliability of our products in the field. Sealevel products are designed and manufactured at its Liberty, South Carolina facility, allowing direct control over product development, production, burn-in and testing. Sealevel achieved ISO-9001:2015 certification in 2018.

## Warranty Policy

Sealevel Systems, Inc. (hereafter "Sealevel") warrants that the Product shall conform to and perform in accordance with published technical specifications and shall be free of defects in materials and workmanship for the warranty period. In the event of failure, Sealevel will repair or replace the product at Sealevel's sole discretion. Failures resulting from misapplication or misuse of the Product, failure to adhere to any specifications or instructions, or failure resulting from neglect, abuse, accidents, or acts of nature are not covered under this warranty.

Warranty service may be obtained by delivering the Product to Sealevel and providing proof of purchase. Customer agrees to ensure the Product or assume the risk of loss or damage in transit, to prepay shipping charges to Sealevel, and to use the original shipping container or equivalent. Warranty is valid only for original purchaser and is not transferable.

This warranty applies to Sealevel manufactured Product. Product purchased through Sealevel but manufactured by a third party will retain the original manufacturer's warranty.

## Non-Warranty Repair/Retest

Products returned due to damage or misuse and Products retested with no problem found are subject to repair/retest charges. A purchase order or credit card number and authorization must be provided in order to obtain an RMA (Return Merchandise Authorization) number prior to returning Product.

## How to obtain an RMA (Return Merchandise Authorization)

If you need to return a product for warranty or non-warranty repair, you must first obtain an RMA number. Please contact Sealevel Systems, Inc. Technical Support for assistance:

Available	Monday – Friday, 8:00AM to 5:00PM EST
Phone	864-843-4343
Email	<a href="mailto:support@sealevel.com">support@sealevel.com</a>

## Trademarks

Sealevel Systems, Incorporated acknowledges that all trademarks referenced in this manual are the service mark, trademark, or registered trademark of the respective company.