

# DIO-16.PCI

User Manual | 8002

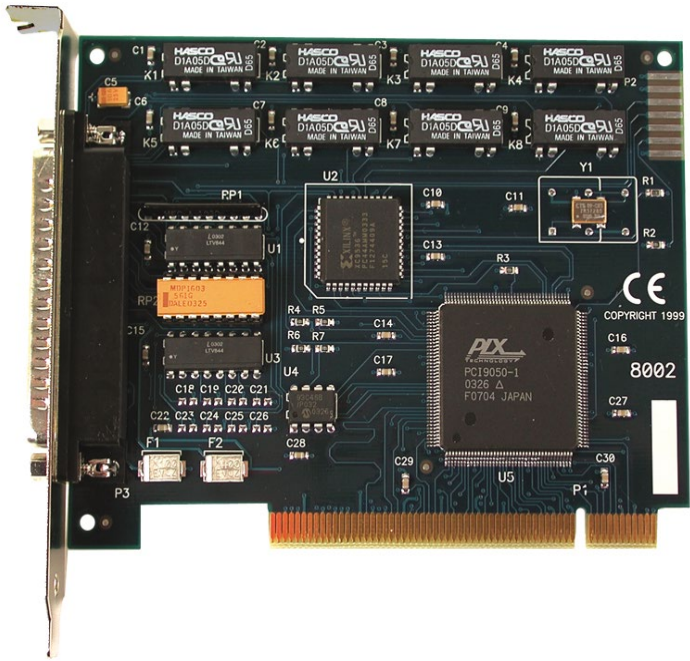

SEALEVEL®

# Contents

- INTRODUCTION .....3
- BEFORE YOU GET STARTED .....4
- SOFTWARE INSTALLATION .....6
- PHYSICAL INSTALLATION.....7
- PROGRAMMING THE DIO-16.PCI .....8
- ELECTRICAL CHARACTERISTICS.....12
- SPECIFICATIONS .....13
- EXAMPLE CIRCUITS.....14
- APPENDIX A – TROUBLESHOOTING .....15
- APPENDIX B – HOW TO GET ASSISTANCE.....16
- APPENDIX C – SILK SCREEN - 8002 PCB.....17
- APPENDIX D – COMPLIANCE NOTICES .....18
- WARRANTY .....19

# Introduction

The DIO-16.PCI provides 8 optically isolated inputs and 8 reed relay outputs. The inputs (rated for 3-13V) protect the PC and other sensitive equipment from spikes and ground loop current that can be generated in industrial environments, while the outputs provide high quality, long life, low current (10 Watt maximum), dry contact switch closures. Reed relays are well suited for low current applications. The relays are normally open and will close when energized. The board is PCI bus specification 2.1 compliant.

The DIO-16.PCI is designed to be used with a variety of Operating Systems including Windows 98/NT/ME/2000/XP, Linux, and DOS. The Seal/O API (Application Programmer Interface) in the software available for the DIO-16.PCI provides a variety of useful high-level function calls implemented as a Windows dynamic link library (DLL) and as a Linux kernel module and library. In addition to the API, Seal/O includes sample code and utilities to simplify software development.

## Other Sealevel USB to Digital I/O Products

PIO-24.PCI	(P/N 8008)	- 24 TTL Inputs/Outputs
PIO-32.PCI	(P/N 8010)	- 32 TTL Inputs/Outputs
PIO-48.PCI	(P/N 8005)	- 48 TTL Inputs/Outputs
PIO-96.PCI	(P/N 8009)	- 96 TTL Inputs/Outputs
REL-16.PCI	(P/N 8003)	- 16 Reed Relay Outputs
DIO-32.PCI	(P/N 8004)	- 16 Reed Relay Outputs/16 Opto-isolated Inputs
ISO-16.PCI	(P/N 8006)	- 16 Opto-isolated Inputs
REL-32.PCI	(P/N 8007)	- 32 Reed Relay Outputs
PLC-16.PCI	(P/N 8011)	- 8 Form C Relay Outputs/8 Opto-isolated Inputs

# Before You Get Started

## What's Included

The DIO-16.PCI is shipped with the following items. If any of these items is missing or damaged, please contact Sealevel for replacement.

- **DIO-16.PCI Adapter**

## Advisory Conventions



### **Warning**

The highest level of importance used to stress a condition where damage could result to the product, or the user could suffer serious injury.



### **Important**

The middle level of importance used to highlight information that might not seem obvious or a situation that could cause the product to fail.



### **Note**

The lowest level of importance used to provide background information, additional tips, or other non-critical facts that will not affect the use of the product.

## Optional Items

Depending upon your application, you are likely to find one or more of the following items useful for interfacing the DIO-16.PCI to real-world signals. All items can be purchased from our website ([www.sealevel.com](http://www.sealevel.com)) or by calling (864) 843-4343.

- **DB-37 Male to DB-37 Female 6' Cable - (Part Number CA112)**
  - This cable extends the DB-37 connector on the REL-16.PCI to six feet and is pinned one-to-one.
- **DB-37 Male/Female Terminal Block (Part Number TB02-KT)**
  - Break out serial and digital connectors to 37 screw terminals for easy field connection. The TB02 terminal block is designed with both DB-37 male and female connectors, therefore; it can be used with any DB-37 board regardless of the board's port gender.
- **Cable and Terminal Block Kit (Part Number KT101)**
  - For convenient and easier ordering, the KT101 includes the TB02-KT terminal block and CA112 cable in a single kit.

# Software Installation

## Windows Installation



Do not install the adapter in the machine until the software has been fully installed.



Only users running Windows 7 or newer should utilize these instructions for accessing and installing the appropriate driver via Sealevel's website. If you are utilizing an operating system prior to Windows 7, please contact Sealevel by calling 864.843.4343 or emailing [support@sealevel.com](mailto:support@sealevel.com) to receive access to the legacy driver download and installation instructions.

1. Select the download for the SealO Classic for Windows ([Software: SealO Classic V5 - Windows - Sealevel](#).) The setup file will automatically detect the operating environment and install the proper components. Next (depending on your browser) select the 'Run this program from its current location' or 'Open' option. Follow the information presented on the screens that follow. During setup, the user may specify installation directories and other preferred configurations. This program also adds entries to the system registry that are necessary for specifying the operating parameters for each driver. An uninstall option is also available to remove SealO files and registry/INI file entries from the system.
2. A screen may appear with the declaration: "The publisher cannot be determined due to the problems below: Authenticode signature not found." Please select the 'Yes' button and proceed with the installation. This declaration simply means that the Operating System is not aware of the driver being loaded. It will not cause any harm to your system.
3. During setup, the user may specify installation directories and other preferred configurations. This program also adds entries to the system registry that are necessary for specifying the operating parameters for each driver. An uninstall option is also included to remove all registry/INI file entries from the system.

Windows software installation is complete.



Windows NT Card Installation: After accomplishing the above steps, bring up the Control Panel and double-click on the SealO Devices icon. To install a new card, click "Add Port". Repeat this procedure for as many SealO cards as you wish to install.



Linux Software: You may download the [SealO Classic for Linux Windows](#) for the 8002. If you need additional information with this installation, please contact Sealevel's Technical Support: [support@sealevel.com](mailto:support@sealevel.com).

# Physical Installation



The adapter can be installed in any 5V PCI expansion slot.

Do not install the adapter in the machine until the software has been fully installed.

1. **Turn off PC power. Disconnect the power cord.**
2. Remove the PC case cover.
3. Locate an available 5V PCI slot and remove the blank metal slot cover.
4. Gently insert the PCI adapter into the slot. Make sure that the adapter is seated properly.
5. After the adapter has been installed, the cables should be routed thru the opening in the bracket. This bracket also features a strain relief function that should be used to prevent un-expected cable removal.
6. Replace the screw you removed for the blank and use it to secure the adapter into the slot. (This is required to ensure FCC Part 15 compliance.)
7. Replace the cover.
8. Connect the power cord

The DIO-16.PCI is now ready for use.

# Programming the DIO-16.PCI

Sealevel's Seal/O software is provided to assist in the development of reliable applications for the Sealevel Systems family of digital I/O adapters. Included in Sealevel's software and drivers are driver functions for use in accessing the I/O as well as helpful samples and utilities.

## Programming for Windows

The Seal/O API (Application Programmer Interface) provides a variety of useful high-level function calls implemented in a Windows dynamic link library (DLL). The API is defined in the help file (Start/Programs/SealO/SealO Help) under "Application Programmers Interface". This help file also includes detailed information dealing with installation / removal of the software and information about latency, logic states, and device configuration.

For C language programmers we recommend using the API to access the DIO-16.PCI. If you are programming in Visual Basic, using the ActiveX control included with Seal/O is advised.

## Samples and Utilities

A variety of sample programs and utilities (both executable and source code) are included in the software for the Seal/O. Further documentation on these samples can be found by selecting "Start/Programs/SealO/Sample Application Description." If you have any problems locating these files, please contact Sealevel's Technical Support at 864-843-4343 or email [support@sealevel.com](mailto:support@sealevel.com).

## Programming for Linux

Seal/O for Linux consists of two major parts: a kernel module and a library. The kernel module is a simple IO pass-through device, allowing the library to handle the more sophisticated functions provided to Seal/O users. It is provided in a 'tarball' format and can easily be compiled and included in the kernel build.

## Digital I/O Interface

The DIO-16.PCI provides two parallel input/output (I/O) ports. The ports are organized as ports A, B, C, and D. Port A is an input port interfaced to optically isolated inputs, while port C is the reed relay output port.

## Input Port

Port A is an eight bit input port connected to optically isolated input sensors. Each sensor can be used to interface a voltage input and then sense whether the voltage is on or off. Each sensor is isolated (with respect to a common ground) from every other sensor, and also isolated with respect to the host PC ground. This means that signals such as low-level AC line voltage, motor servo voltage, and control relay signals can be 'sensed', or read by the PC, without the risk of damage due to ground loops or ground faults.

Each sensor input pair has a current limiting resistor that is used to limit the input current to the opto-isolator. The opto-isolator has two 'back-to-back' diodes internally. This allows AC or DC signals to be sensed, regardless of polarity. When the applied voltage is high enough to cause the led in the opto-isolator to turn-on, the output of the opto-isolator goes low (0 volts), and the signal is read as a low logic level (binary



0) by the PC. When the input signal is too low to turn on the opto-isolator, the output goes high, and the port bit is read by the PC as a high logic level (binary 1).

The input impedance of each isolated input is approximately 560 ohms (factory default). The opto-isolator requires approximately 3mA to turn on. The maximum input current is 50mA. There are two things to consider when selecting the input resistor. The first is turn on voltage for the circuit to sense, and second is the maximum input voltage. Maximum input voltage must not provide too much power to the input resistor and must also not overdrive the opto-isolator input current specification. The following formulas apply:

$$\text{Turn on Voltage} = \text{diode drop} + (\text{turn on current}) \times (\text{resistance}) \quad [\text{Ex: } 1.1 + (.003) \times R]$$

$$\text{Input Current} = ((\text{input voltage}) - 1.1\text{V}) / (\text{resistor value})$$

$$\text{Maximum voltage} = 1.1 + \text{square root of } (.25(\text{resistor value}))$$

The following table shows common input resistors and the ranges associated with each.

Input Resistor	Turn-On	Input Range	Max Input	Max Current
220W	1.8V	1.8 – 7.0V	8.5V	27mA
560W	2.8V	2.8 – 10.6V	12.9V	20mA
1KW	4.1V	4.1 – 13.8V	16.9V	15mA
2.2KW	7.7V	7.7 – 20.0V	24.5V	10mA
3.3KW	10.0V	10.0 – 24.0V	30.0V	9mA
4.7KW	15.2V	15.2 – 28.0V	35.0V	7mA



The turn-off voltage for all resistors is less than 1V.

Increasing the input resistor accordingly can increase the maximum input voltage. Because socketed DIP resistors are utilized, they can easily be replaced with a different value. Sealevel, if necessary, can do this.



The input circuits are not intended for monitoring 120-volt AC circuits. In addition to being too high a voltage for the circuits, it is dangerous to have that high a voltage on the card.

## Input Port Pin Assignments (DB-37 Male)

Port A Bit	P1
0	2,20
1	3,21
2	4,22
3	5,23
4	6,24
5	7,25
6	8,26
7	9,27

## Output Ports (Reed Relays)

Reed relays provide very high quality, long life, low current (10 Watt maximum), dry contact switch closures. Reed relays are not suited for high current applications, and can be destroyed by inductive load switching, where a spark occurs across the contacts internally. The relays are normally open, and close when energized.

## Output Port Pin Assignments

Port C Bit	Relay	P2 Pin
0	K1	10,28
1	K2	11,29
2	K3	12,30
3	K4	13,31
4	K5	14,32
5	K6	15,33
6	K7	16,34
7	K8	17,35

## Power and Ground Pin Assignments

Ground	18,36,37
+ 5 Volts	19
+ 12 Volts	1

## Direct Hardware Control

In systems where the user's program has direct access to the hardware (i.e. DOS) the table below gives the mapping and functions that the **DIO-16.PCI** provides.

R = Read  
R/W = Read or Write

Function Available	Port	Address Hex	Port Type
RD	A	Base+0	Input Port (Opto Input)
	B	Base+1	Not Assigned
R/W	C	Base+2	Output Port (Reed Relays)
	D	Base+3	Not Assigned

*RD = Read, RD/WR = Read or Write*

## Reading the Inputs

The inputs are active Low. If no voltage is applied across one of the differential inputs, it returns a one on that bit. If an AC or DC voltage is applied, it returns a zero on that bit.

## Reading the Outputs

The relay ports return the ones complement of the value that is currently being used to drive the relays.

## Writing the Outputs

The output ports are the only ports that can be written. The relays on a standard DIO-32.PCI are normally open. To close a relay a one must be written to the appropriate bit.

## Register Description

All ports are set to input after reset or power up.

Address	Mode	D7	D6	D5	D4	D3	D2	D1	D0
<b>Base+0</b>	RD	PAD7	PAD6	PAD5	PAD4	PAD3	PAD2	PAD1	PAD0
<b>Base+1</b>	RD	{0}	{0}	{0}	{0}	{0}	{0}	{0}	{0}
<b>Base+2</b>	RD/WR	PCD7	PCD6	PCD5	PCD4	PCD3	PCD2	PCD1	PCD0
<b>Base+3</b>	RD	{0}	{0}	{0}	{0}	{0}	{0}	{0}	{0}
<b>Base+4</b>	RD	{0}	{0}	{0}	{0}	{0}	{0}	{0}	{0}
<b>Base+5</b>	RD/WR	IRQEN	IRQST	{0}	{0}	{0}	{0}	IRC1	IRC0
<b>Base+6</b>	RD	{0}	{0}	{0}	{0}	{0}	{0}	{0}	{0}
<b>Base+7</b>	RD	{0}	{0}	{0}	{0}	{0}	{0}	{0}	{0}

## Interrupt Control

When enabled, interrupts are generated on Port A bit D0.

<b>IRQEN</b>	Interrupt enable	1 = enabled	0 = disabled (0 on power up)
<b>IRC0</b>	Interrupt mode select, see table below		
<b>IRC1</b>	Interrupt mode select, see table below		

## Interrupt Mode Select Table

Interrupt source is Base+0 bit D0. When selecting the Interrupt Type, always disable interrupts prior to changing or setting states. This will help prevent inadvertent or unexpected interrupts from occurring.

IRC1	IRC0	Interrupt Type
0	0	Low Level
0	1	High Level
1	0	Falling Edge
1	1	Rising Edge



When using the High and Low Level interrupts, an interrupt occurs when input D0 changes to either a High or Low state. This will cause the computer to remain in an interrupt state until the input state changes.

## Interrupt Read

Reading the Interrupt Status port (Base+5) clears any interrupt pending.

<b>IRQST</b>	(D0) Interrupt Status	1 = interrupt pending, 0 = none
--------------	-----------------------	---------------------------------

# Electrical Characteristics

## Features

- 8 SPST relays
- 1 eight bit optically isolated input port
- DB-37 Male connector
- Highly reliable 10 VA DIP reed relays
- Multiple adapters can reside in same computer
- PCI 2.1 Bus compatible

# Specifications

## Input Ports

Turn On Current	3mA
Isolator Diode Drop	1.1 VDC
Resistor Power Max	.25 W
Maximum Input Range	3 – 13 VDC/VAC

## Output Relays

Contact Max Power Rating	10W
Contact Voltage Maximum	100 VDC/VAC
Contact Current Maximum	.5A AC/DC RMS
Contact Resistance, Initial	.15 $\Omega$
Rated Life	Low Load: 200 Million closures Maximum Load: 100 Million closures
Contact Speed	Operate: .5 mS Release: .5 mS Bounce: .5 mS

## Temperature Range

Operating	0°C - 70°C
Storage	-50°C - 105°C

## Power Consumption

Supply line	+5 VDC
Rating	280 mA

## Physical Dimensions

PCB Length	5.0 inches (12.7 cm)
PCB Height	3.9 inches (9.9 cm, including Gold Fingers)

## Manufacturing

All Sealevel Systems Printed Circuit boards are built to UL 94V0 rating and are 100% electrically tested. These printed circuit boards are solder mask over bare copper or solder mask over tin nickel.

## Example Circuits

Input Circuit

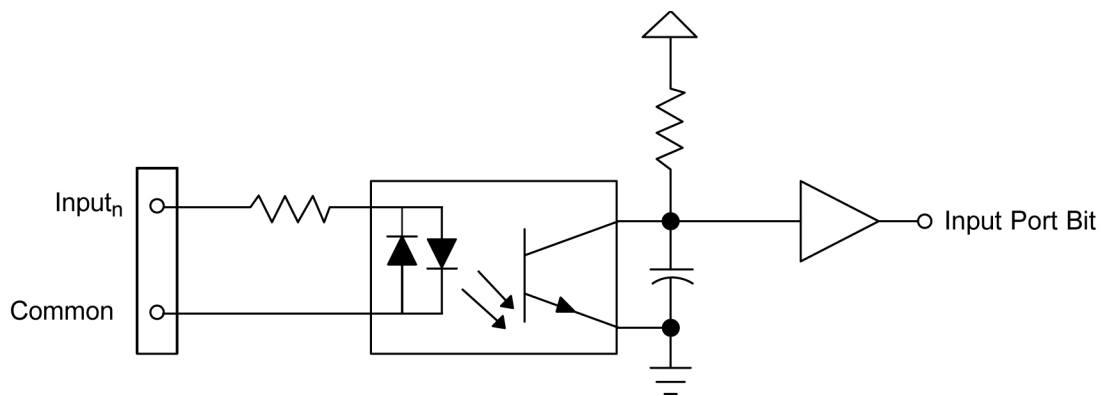

Output Circuit

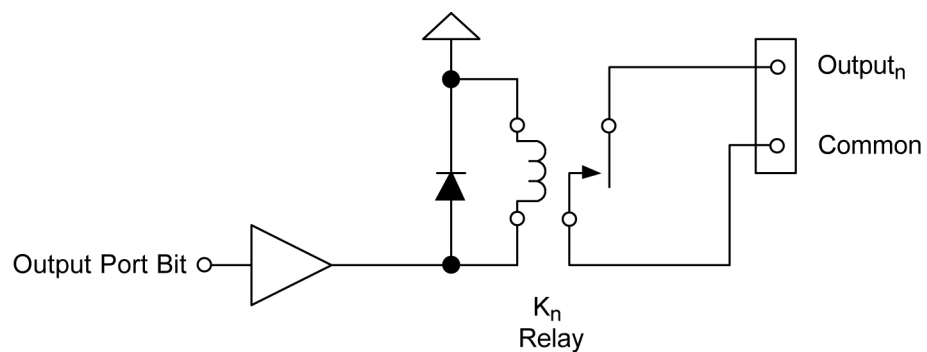

# Appendix A – Troubleshooting

Following these simple steps can eliminate most common problems.

1. **Install software first.** After installing the software then proceed to adding the hardware. This places the required installation files in the correct locations.
2. Read this manual thoroughly before attempting to install the adapter in your system.
3. Use Device Manager under Windows to verify proper installation.
4. Use the SealIO Control Panel applet or the Device Manager's property page for card identification and configuration.

If these steps do not solve your problem, please call Sealevel Systems' Technical Support, (864) 843-4343. Our technical support is free and available Monday through Friday from 8:00 AM - 5:00 PM, Eastern Time. For email support contact [support@sealevel.com](mailto:support@sealevel.com).

# Appendix B – How To Get Assistance

Begin by reading through the Troubleshooting Guide in [Appendix A](#). If assistance is still needed, please see below.

When calling for technical assistance, please have your user manual and current adapter settings. If possible, please have the adapter installed in a computer ready to run diagnostics.

Sealevel Systems provides an FAQ section on its web site. Please refer to this to answer many common questions. This section can be found at <http://www.sealevel.com/faq.asp>.

Sealevel Systems maintains a Home page on the Internet. Our home page address is [www.sealevel.com](http://www.sealevel.com). The latest software updates, and newest manuals are available via our FTP site that can be accessed from our home page.

Technical support is available Monday to Friday from 8:00 AM to 5:00 PM, Eastern Time. Technical support can be reached at (864) 843-4343. For email support contact [support@sealevel.com](mailto:support@sealevel.com).

**RETURN AUTHORIZATION MUST BE OBTAINED FROM SEALEVEL SYSTEMS BEFORE RETURNED MERCHANDISE WILL BE ACCEPTED. AUTHORIZATION CAN BE OBTAINED BY CALLING SEALEVEL SYSTEMS AND REQUESTING A RETURN MERCHANDISE AUTHORIZATION (RMA) NUMBER.**



# Appendix C – Silk Screen - 8002 PCB

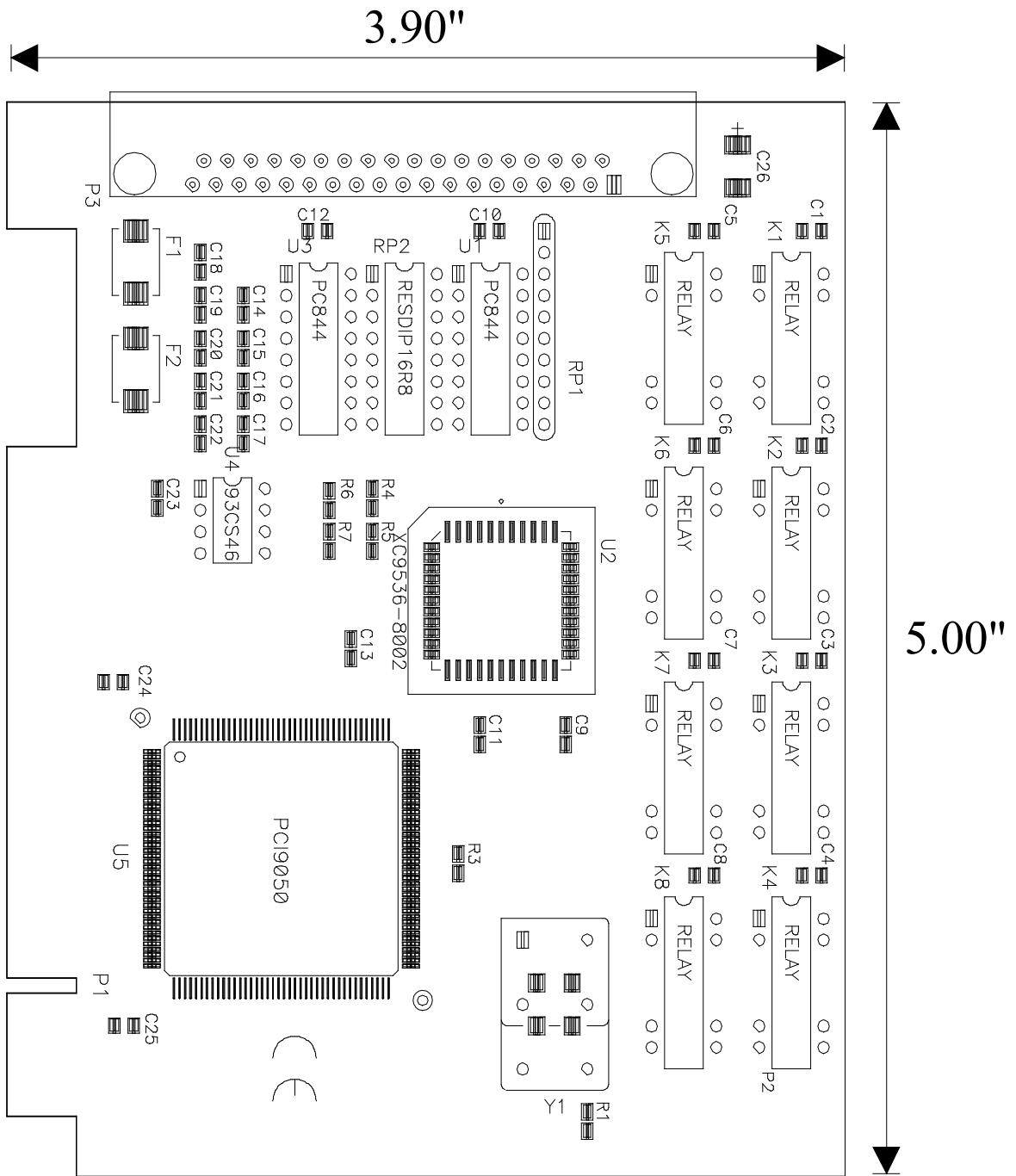

# Appendix D – Compliance Notices

## Federal Communications Commission (FCC) Statement



This equipment has been tested and found to comply with the limits for Class A digital device, pursuant to Part 15 of the FCC Rules. These limits are designed to provide reasonable protection against harmful interference when the equipment is operated in a commercial environment. This equipment generates, uses, and can radiate radio frequency energy and, if not installed and used in accordance with the instruction manual, may cause harmful interference to radio communications. Operation of this equipment in a residential area is likely to cause harmful interference in such case the user will be required to correct the interference at the users expense.

## EMC Directive Statement



Products bearing the CE Label fulfill the requirements of the EMC directive (89/336/EEC) and of the low-voltage directive (73/23/EEC) issued by the European Commission. To obey these directives, the following European standards must be met:

- **EN55022 Class A** - "Limits and methods of measurement of radio interference characteristics of information technology equipment"
- **EN55024** - "Information technology equipment Immunity characteristics Limits and methods of measurement".



This is a Class A Product. In a domestic environment, this product may cause radio interference in which case the user may be required to take adequate measures to prevent or correct the interference.



Always use cabling provided with this product if possible. If no cable is provided or if an alternate cable is required, use high quality shielded cabling to maintain compliance with FCC/EMC directives.

# Warranty

Sealevel's commitment to providing the best I/O solutions is reflected in the Lifetime Warranty that is standard on all Sealevel manufactured I/O products. We are able to offer this warranty due to our control of manufacturing quality and the historically high reliability of our products in the field. Sealevel products are designed and manufactured at its Liberty, South Carolina facility, allowing direct control over product development, production, burn-in and testing. Sealevel achieved ISO-9001:2015 certification in 2018.

## Warranty Policy

Sealevel Systems, Inc. (hereafter "Sealevel") warrants that the Product shall conform to and perform in accordance with published technical specifications and shall be free of defects in materials and workmanship for the warranty period. In the event of failure, Sealevel will repair or replace the product at Sealevel's sole discretion. Failures resulting from misapplication or misuse of the Product, failure to adhere to any specifications or instructions, or failure resulting from neglect, abuse, accidents, or acts of nature are not covered under this warranty.

Warranty service may be obtained by delivering the Product to Sealevel and providing proof of purchase. Customer agrees to ensure the Product or assume the risk of loss or damage in transit, to prepay shipping charges to Sealevel, and to use the original shipping container or equivalent. Warranty is valid only for original purchaser and is not transferable.

This warranty applies to Sealevel manufactured Product. Product purchased through Sealevel but manufactured by a third party will retain the original manufacturer's warranty.

## Non-Warranty Repair/Retest

Products returned due to damage or misuse and Products retested with no problem found are subject to repair/retest charges. A purchase order or credit card number and authorization must be provided in order to obtain an RMA (Return Merchandise Authorization) number prior to returning Product.

## How to obtain an RMA (Return Merchandise Authorization)

If you need to return a product for warranty or non-warranty repair, you must first obtain an RMA number. Please contact Sealevel Systems, Inc. Technical Support for assistance:

Available	Monday – Friday, 8:00AM to 5:00PM EST
Phone	864-843-4343
Email	<a href="mailto:support@sealevel.com">support@sealevel.com</a>

## Trademarks

Sealevel Systems, Incorporated acknowledges that all trademarks referenced in this manual are the service mark, trademark, or registered trademark of the respective company.