

PC-COMM+2.ULTRA

User Manual | 3623



SEALEVEL®

Contents

CONTENTS.....2

INTRODUCTION3

BEFORE YOU GET STARTED5

INSTALLING THE PC-COMM+2.ULTRA.....6

HARDWARE SPECIFICATION7

USING THE PC-COMM+2.ULTRA CARD IN RS-422/485 MODE12

APPENDIX A – TROUBLESHOOTING.....14

APPENDIX B – HOW TO GET ASSISTANCE15

APPENDIX C – COMPLIANCE NOTICES16

WARRANTY17

Introduction

The PC-COMM+2.ULTRA card is a dual-port multi-interface asynchronous serial card using a 16550 compatible UART ASIC device. The serial data and control lines on both ports are buffered using ESD protected, hardware configurable RS-232, RS-422/485 multi-protocol transceivers.

Industry standard baud rates up to 921.6K bps are supported, together with 16-byte TX and RX FIFOs. DIP switches on the rear of the card allow selection of “x1” or “x8” baud rate multipliers for each port. This feature allows up to 921.6K bps operation without needing special device drivers on the host (in “x8” mode you simply multiply the setting shown on the host by 8 to get the real serial data rate - e.g., 19.2K bps set in software with “x8” mode gives 153.6K bps data rate physically in hardware). See [Section 4](#) for the switch settings.



The baud rate multiplier (“x1” and “x8”) is common to both ports.

Along with the baud rate multiplier, the DIP switches on the rear of the card also control the selection of the following:

- RS-232 or RS-422/485 mode
- Half or full duplex in RS-485 mode
- Auto-TX enable, or RTS-override-TX enable in RS-485 half-duplex mode
- Local TX character echo enable/disable in RS-485 half-duplex mode

Features

The PC-COMM+2.ULTRA is a dual-port RS-232/422/485 PCMCIA serial card with the following features:

- Dual 16C550 buffered UARTS with 16-byte FIFOs
- Each port individually configurable for RS-232, RS-422, or RS-485
- Each port individually configurable for RS-485 full or half-duplex mode (in-card connection of TXD and RXD signals in half duplex mode)
- RS-422 mode includes differential RTS and CTS modem control signals and permanently enabled TX driver and receiver
- Each port individually configurable between Auto-TX enable and RTS-override-TX enable when in RS-485 half-duplex mode
- Configuration of local TX character echoing when in RS-485 half-duplex mode (common to both ports)
- Automatic RS-485 tri-state enable/disable
- Switchable x1 or x8 baud rate multiplier supports up to 921.6K bps (common to both ports)
- Windows 95 OSR2, 98, 98SE, Me, 2000, and XP compatible using standard drivers
- True multi-function Type II design
- 3.3V or 5V compatible
- All modem control signals implemented on both ports in RS-232 mode
- ESD protection on drivers and receivers
- TX drivers fitted with short-circuit and thermal overload protection.
- Low power consumption
- Detachable 12" Y-cable with dual DB-25M connectors

Before You Get Started

What's Included

The PC-COMM+2.ULTRA is shipped with the following items. If any of these items are missing or damaged, please contact Sealevel for replacement.

- **PC-COMM+2.ULTRA**

Advisory Conventions



Warning

The highest level of importance used to stress a condition where damage could result to the product, or the user could suffer serious injury.



Important

The middle level of importance used to highlight information that might not seem obvious or a situation that could cause the product to fail.



Note

The lowest level of importance used to provide background information, additional tips, or other non-critical facts that will not affect the use of the product.

Installing the PC-COMM+2.ULTRA

3.1 Windows 95 OSR2, 98, 98E, Me, 2000, XP

You will first need to install SeaCOM prior to using the PC-COMM+2.ULTRA. You **must** reboot the PC after installation to allow the COM ports to be assigned port numbers by the operating system.

1. Begin by clicking this link to download [SeaCOM for Windows](#).
2. Select 'Download Now' for the SeaCOM for Windows. The setup file will automatically detect the operating environment and install the proper components. Next (depending on your browser) select the 'Run this program from its current location' or 'Open' option. Follow the information presented on the screens that follow.
3. A screen may appear with the declaration: "The publisher cannot be determined due to the problems below: Authenticode signature not found." Please select the 'Yes' button and proceed with the installation. This declaration simply means that the Operating System is not aware of the driver being loaded. It will not cause any harm to your system.
4. During setup, the user may specify installation directories and other preferred configurations. This program also adds entries to the system registry that are necessary for specifying the operating parameters for each driver. An uninstall option is also included to remove all registry/INI file entries from the system.

For Windows 95/98/ME/NT/2000, the diagnostic tool 'WinSSD' is installed in the SeaCOM folder on the Start Menu during the setup process. First find the ports using the Device Manager, then use 'WinSSD' to verify that the ports are functional.

3.2 Windows CE, PocketPC

The PC-COMM+2.ULTRA will not work with either of these operating systems because of a limitation in the handling of true multi-function PC-Cards.

If you need assistance with your installation, please call Sealevel Systems' Technical Support, (864) 843-4343. Our technical support is free and available from 8:00 AM to 5:00 PM Eastern Time Monday through Friday. For email support contact support@sealevel.com.

Hardware Specification

4.1 Pinout

The PC-COMM+2.ULTRA is supplied with a 12" Y-cable that terminates with two DB-25M connectors with female jackscrews. When the PC-COMM+2.ULTRA is used in RS-232 mode, the pinout matches that of a standard RS-232 serial port.

The pinouts below apply to **both** of the PC-COMM+2.ULTRA DB-25M connectors.

Both DB-25M Pinouts – RS-232 Mode

PIN	NAME	FUNCTION
1	-	-
2	TXD	Transmit Data output
3	RXD	Receive Data input
4	RTS	Request To Send output
5	CTS	Clear To Send input
6	DSR	Data Set Ready input
7	GND	GROUND
8	DCD	Data Carrier Detect input
9	-	-
10	-	-
11	RTS+	RS-422 output. Held low in RS-232 Mode
12	-	-
13	-	-
14	-	-
15	-	-
16	-	-
17	-	-
18	-	-
19	-	-
20	DTR	Data Terminal Ready output
21	-	-
22	RI	Ring Indicate input
23	-	-
24	-	-
25	-	-



Please terminate any control signals that are not going to be used. The most common way to do this is connect RTS to CTS and RI. Also, connect DCD to DTR and DSR. Terminating these pins, if not used, will help insure you get the best performance from your adapter.

Both DB-25M Pinouts – RS-422/485 Mode

PIN	NAME	FUNCTION
1	-	-
2	TXD-	Transmit Data inverting output
3	RXD+	Receive Data non-inverting input
4	RTS-	Request To Send inverting output
5	CTS+	Clear To Send non-inverting input
6	CTS-	Clear To Send inverting input
7	GND	GROUND
8	RXD-	Receive Data inverting input
9	-	-
10	-	-
11	RTS+	Request To Send non-inverting output
12	-	-
13	-	-
14	-	-
15	-	-
16	-	-
17	-	-
18	-	-
19	-	-
20	TXD+	Transmit Data non-inverting output
21	-	-
22	RI	RS-232 input. Receiver disabled in RS-422/485 Mode
23	-	-
24	-	-
25	-	-



Please terminate any control signals that are not going to be used. The most common way to do this is connect RTS- to CTS- and connect RTS+ to CTS+. Terminating these pins, if not used, will help insure you get the best performance from your adapter.

4.2 Electrical

All figures quoted are typical parameters @ 25°C (77°F)

- RS-232 SIGNALS:** Minimum output level $\pm 5.0V$
- RS-422 SIGNALS:** Minimum differential output level 2V
- RS-485 SIGNALS:** Minimum differential output level 1.5V

ESD PROTECTION: All signal lines are protected against electrostatic discharge to 2kV

UART CLOCK SPEED: Switch selectable Baud rate multiplier per port:

x1: UART CLOCK is 1.8432MHz ->115.2K bps max

x8: UART CLOCK is 14.7456MHz->921.6K bps max

4.3 Power Supply

All figures quoted are typical parameters @ 25°C (77°F)

- SUPPLY VOLTAGE:** 3.3V or 5V.
- SUPPLY CURRENT:** 25mA typical at 5V with no connections
- 55mA typical at 5V, RS232 mode, 921K bps TX & RX both ports
- 70mA typical at 5V, RS422/RS485, 921K bps TX & RX both ports

4.4 Mechanical

- MASS:** 12g typical (0.423 oz)
- FORM FACTOR:** Typell PC-Card

4.5 Environmental

- HUMIDITY:** <80% R.H. (non-condensing)
- TEMP:** 0-50°C ambient (32-122°F)

4.6 Notes on Serial Data Throughput

The maximum bit rate of 921.6K bps does not imply that the maximum sustained throughput rate of the serial port will be as high. The actual throughput that can be achieved depends on many factors including the host PC speed, the serial data block size, duty cycle, and overall host interrupt latency.

4.7 PC-COMM+2.ULTRA Mode Configuration

The PC-COMM+2.ULTRA can be configured using a small bank of DIP switches arranged at the rear of the PC-Card. The diagram below shows the function of each switch. The switches should be set to the desired mode of operation before the card is inserted and used.

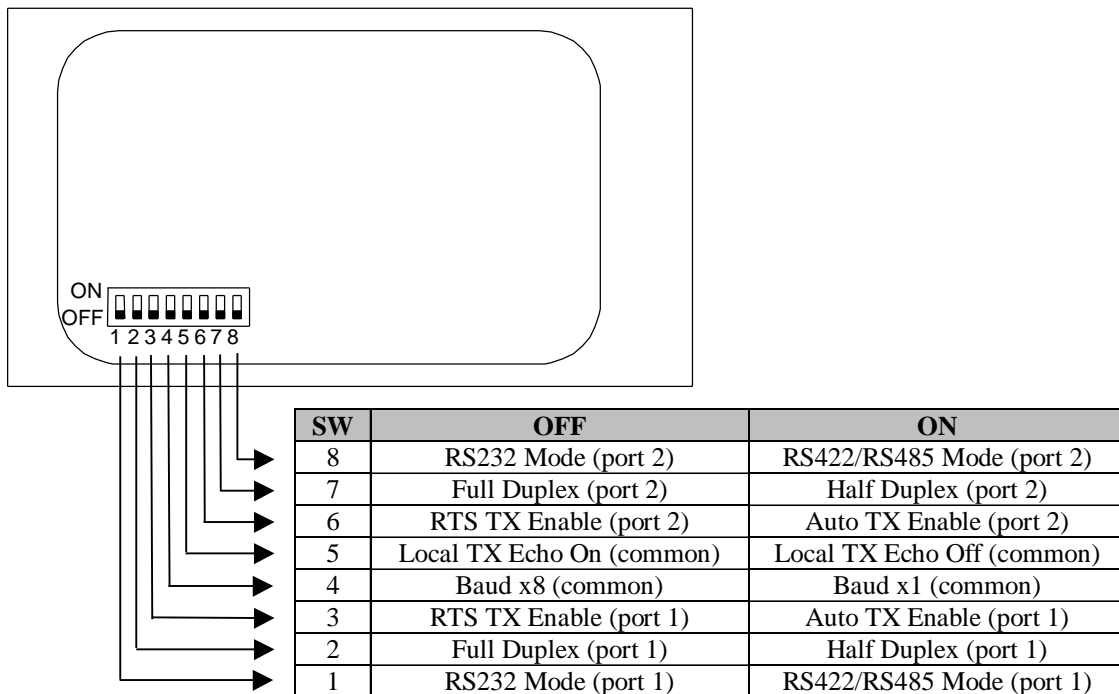

Figure 5.7-1 PC-COMM+2.ULTRA DIP Switch Settings

4.7.1 RS-232 or RS-422/485 Mode Selection

Switches 1 and 8 control the electrical interface selection for ports 1 and 2 respectively.

4.7.2 Full or Half Duplex Selection

Switches 2 and 7 control the duplex selection for ports 1 and 2 respectively when in RS-422/485 mode. When set to half duplex, the receiver inputs for the RXD and CTS signals are connected internally to the driver outputs of the TXD and RTS signals, respectively. The RXD and CTS pins themselves however become open circuit, so all connections in half-duplex mode should be made via the TXD and RTS pins.

The duplex selection switches have no effect when the ports are in RS-232 mode.

4.7.3 RTS or Auto TX Enable Selection

Switches 3 and 6 control the TXD driver enable signal selection for ports 1 and 2 respectively when in RS-485 half-duplex mode. When set to RTS, the transmitter is enabled when the RTS signal of the UART is asserted. The transmitter is tri-stated when the RTS signal is negated.

If the TX Enable Selection switch is set to Auto, the TXD driver is automatically enabled by the hardware only when data is in the process of being transmitted.

4.7.4 Local TX Echo On/Off Selection

Switch 5 controls the local TX echo on/off selection. This setting is common to both ports. When Echo is set to on, the card not only receives data from other devices, but it also receives echoes from its own transmitter. By setting echo to off, the TX Enable signal is used to disable the local receiver when the TXD driver is activated.



Only set Local TX Echo to off when in RS-485 half-duplex mode. Because the TXD driver is always activated when full duplex mode is selected, the receiver would always be disabled if echo was set to off in this mode.

4.7.5 Baud Rate Multiplier Selection

Switch 4 controls the Baud rate multiplier selection. This setting is common to both ports. The table below illustrates the baud rate values available for each position of the switch:

HOST SETTING	SWITCH = x1	SWITCH = x8
300 bps	300 bps	2400 bps
1200 bps	1200 bps	9600 bps
2400 bps	2400 bps	19.2K bps
4800 bps	4800 bps	38.4K bps
9600 bps	9600 bps	76.8K bps
19.2K bps	19.2K bps	153.6K bps
38.4K bps	38.4K bps	307.2K bps
57.6K bps	57.6K bps	460.8K bps
115.2K bps	115.2K bps	921.6K bps

Using the PC-COMM+2.ULTRA Card in RS-422/485 Mode

5.1 Termination

In most cases terminating resistors are required on either end of a RS-422/485 network. This is to eliminate spurious data reflections in the cable. The most common method of termination is to install a terminating resistor, typically with a value of 120-Ohm.

The PC-COMM+2.ULTRA does not have internal terminating resistors. If required, a 120-Ohm resistor should be connected between the RXD+/- pins of the DB-25 connector for full-duplex operation and across the TXD+/- pins in half-duplex mode. For RS-422 applications, a terminating resistor will also be required between the CTS+ and CTS- pins.

5.2 RS-422/485 Receiver Biasing Characteristics

When an RS-422/485 bus is shorted, open circuited, or idle, the differential bus voltage will go to zero. Unfortunately, this is in the middle of the specified RS-422/485 receiver threshold range of +/-200mV, so the receiver output state is indeterminate under both fault conditions and when no driver is actively driving the bus.

The PC-COMM+2.ULTRA card overcomes these problems by using transceivers with a precise receiver threshold range of -50mV to -200mV. If the differential receiver input voltage is greater than -50mV or less than -200mV, the receiver output is logic high or logic low respectively. In the case of a terminated bus with all transmitters disabled, the differential input voltage of the receiver is pulled to GND by the termination. This results in a logic high with a 50mV minimum noise margin.

5.3 TXD and RTS Drivers

The RTS signal driver on the PC-COMM+2.ULTRA is always enabled when in RS-422/485 mode, regardless of any other setting.

In addition to the standard method of tri-stating the TXD signal in RS-485 mode using the RTS signal, the PC-COMM+2.ULTRA incorporates an automatic tri-state feature. The driver is enabled only when data is in the process of being transmitted. This mechanism removes the burden of flow control from the application software.



When multiple characters are transmitted “back-to-back” the output drivers stay active for the entire duration of the transmission (i.e., the drivers do not go in and out of tri-state for each character in a multi-character block).

5.4 RS-422 Operation

In RS-422 systems, all 8 signal lines from the DB-25 connector are used. Thus 4 twisted pair cables are used, one pair for each of the 4 signals TXD, RXD, RTS and CTS. The RS-422 arrangement allows data to be transmitted and received simultaneously since each signal has its own twisted pair.

5.5 RS-485 Operation

The PC-COMM+2.ULTRA can be used for both half-duplex (one twisted pair) and full-duplex (two twisted pairs) arrangements. In half-duplex mode, the link between the TXD and RXD signals is made internally.

The handshaking signals RTS and CTS, although driven by the card, are usually not connected to another node. However, if required by the application software, to force the CTS signal input on the PC-COMM+2.ULTRA true, the RTS signals must be looped back to the CTS inputs. In half-duplex mode, the card makes this link internally. However, in full-duplex mode the link must be made externally.

Appendix A – Troubleshooting

The adapter should provide years of trouble-free service. However, in the event that device appears to not be functioning incorrectly, the following tips can eliminate most common problems without the need to call Technical Support.

1. Identify all I/O adapters currently installed in your system. This includes your on-board serial ports, controller cards, sound cards, etc. The I/O addresses used by these adapters, as well as the IRQ (if any) should be identified.
2. Configure your Sealevel Systems adapter so that there is no conflict with currently installed adapters. No two adapters can occupy the same I/O space.
3. Try the Sealevel Systems adapter with a unique IRQ. While the Sealevel Systems adapter does allow the sharing of IRQs, many other adapters (i.e., SCSI adapters & on-board serial ports) do not.
4. Make sure the Sealevel Systems adapter is securely installed.
5. For Windows 95/98/ME/NT/2000, the diagnostic tool '[WinSSD](#)' is installed in the SeaCOM folder on the Start Menu during the setup process. First find the ports using the Device Manager, then use 'WinSSD' to verify that the ports are functional.
6. Remember, if 'No Echo' mode is selected, a data loopback cannot be accomplished.
7. Always use the Sealevel Systems diagnostic software when troubleshooting a problem. This will eliminate any software issues from the equation.

If these steps do not solve your problem, please call Sealevel Systems' Technical Support, (864) 843-4343. Our technical support is free and available from 8:00 AM to 5:00 PM Eastern Time Monday through Friday. For email support contact support@sealevel.com.

Appendix B – How To Get Assistance

Please refer to Troubleshooting Guide prior to calling Technical Support.

1. Begin by reading through the Trouble Shooting Guide in Appendix A. If assistance is still needed please see below.
2. When calling for technical assistance, please have your user manual and current adapter settings. If possible, please have the adapter installed in a computer ready to run diagnostics.
3. Sealevel Systems provides an FAQ section on its web site. Please refer to this to answer many common questions. This section can be found at <http://www.sealevel.com/faq.htm> .
4. Sealevel Systems maintains a Home page on the Internet. Our home page address is www.sealevel.com. The latest software updates, and newest manuals are available via our FTP site that can be accessed from our home page.
5. Technical support is available Monday to Friday from 8:00 A.M. to 5:00 P.M. Eastern time. Technical support can be reached at (864) 843-4343.

RETURN AUTHORIZATION MUST BE OBTAINED FROM SEALEVEL SYSTEMS BEFORE RETURNED MERCHANDISE WILL BE ACCEPTED. AUTHORIZATION CAN BE OBTAINED BY CALLING SEALEVEL SYSTEMS AND REQUESTING A RETURN MERCHANDISE AUTHORIZATION (RMA) NUMBER.

Appendix C – Compliance Notices

Federal Communications Commission (FCC) Statement



This equipment has been tested and found to comply with the limits for Class A digital device, pursuant to Part 15 of the FCC Rules. These limits are designed to provide reasonable protection against harmful interference when the equipment is operated in a commercial environment. This equipment generates, uses, and can radiate radio frequency energy and, if not installed and used in accordance with the instruction manual, may cause harmful interference to radio communications. Operation of this equipment in a residential area is likely to cause harmful interference in such case the user will be required to correct the interference at the user's expense.

EMC Directive Statement



Products bearing the CE Label fulfill the requirements of the EMC directive (89/336/EEC) and of the low-voltage directive (73/23/EEC) issued by the European Commission. To obey these directives, the following European standards must be met:

- **EN55022 Class A** - "Limits and methods of measurement of radio interference characteristics of information technology equipment"
- **EN55024** – "Information technology equipment Immunity characteristics Limits and methods of measurement".



This is a Class A Product. In a domestic environment, this product may cause radio interference in which case the user may be required to take adequate measures to prevent or correct the interference.



Always use cabling provided with this product if possible. If no cable is provided or if an alternate cable is required, use high quality shielded cabling to maintain compliance with FCC/EMC directives.

Canadian Radio Interference Regulations

This Class B digital apparatus meets all requirements of the Canadian Interference-Causing Equipment Regulations.

Cet Appareil numérique de la classe B respecte toutes les exigences de Règlement sur le matériel du Canada

Warranty

Sealevel's commitment to providing the best I/O solutions is reflected in the Lifetime Warranty that is standard on all Sealevel manufactured I/O products. We are able to offer this warranty due to our control of manufacturing quality and the historically high reliability of our products in the field. Sealevel products are designed and manufactured at its Liberty, South Carolina facility, allowing direct control over product development, production, burn-in and testing. Sealevel achieved ISO-9001:2015 certification in 2018.

Warranty Policy

Sealevel Systems, Inc. (hereafter "Sealevel") warrants that the Product shall conform to and perform in accordance with published technical specifications and shall be free of defects in materials and workmanship for the warranty period. In the event of failure, Sealevel will repair or replace the product at Sealevel's sole discretion. Failures resulting from misapplication or misuse of the Product, failure to adhere to any specifications or instructions, or failure resulting from neglect, abuse, accidents, or acts of nature are not covered under this warranty.

Warranty service may be obtained by delivering the Product to Sealevel and providing proof of purchase. Customer agrees to ensure the Product or assume the risk of loss or damage in transit, to prepay shipping charges to Sealevel, and to use the original shipping container or equivalent. Warranty is valid only for original purchaser and is not transferable.

This warranty applies to Sealevel manufactured Product. Product purchased through Sealevel but manufactured by a third party will retain the original manufacturer's warranty.

Non-Warranty Repair/Retest

Products returned due to damage or misuse and Products retested with no problem found are subject to repair/retest charges. A purchase order or credit card number and authorization must be provided in order to obtain an RMA (Return Merchandise Authorization) number prior to returning Product.

How to obtain an RMA (Return Merchandise Authorization)

If you need to return a product for warranty or non-warranty repair, you must first obtain an RMA number. Please contact Sealevel Systems, Inc. Technical Support for assistance:

Available	Monday – Friday, 8:00AM to 5:00PM EST
Phone	864-843-4343
Email	support@sealevel.com

Trademarks

Sealevel Systems, Incorporated acknowledges that all trademarks referenced in this manual are the service mark, trademark, or registered trademark of the respective company.